



Test Report issued under the responsibility of:

intertek
Total Quality. Assured.

**TEST REPORT
IEC 60669-2-1**

**Switches for household and similar fixed-electrical installations
Part 2-1: Particular requirements - Electronic switches**

Report Number: 201119013GZU-001

Date of issue: 23 November 2020

Total number of pages: 95

Name of Testing Laboratory preparing the Report: Intertek Testing Services Shenzhen Ltd. Guangzhou Branch

Applicant's name: TCL-Legrand International Electrical (Huizhou) Co., Ltd.

Address: Bldg. B1-B3, East No.39 Hechang 6th Rd., HZZK Hi-tech Industrial Development Zone, Huizhou, Guangdong, China

Test specification:

Standard: IEC 60669-2-1:2002/AMD1:2008/AMD2:2015 used in conjunction with IEC 60669-1:1998 /AMD1:1999/AMD2:2006

Test procedure.....: CB Scheme

Non-standard test method.....: N/A

Test Report Form No......: IEC60669_2_1G

Test Report Form(s) Originator.....: IMQ S.p.A.

Master TRF: Dated 2016-11

Copyright © 2016 IEC System of Conformity Assessment Schemes for Electrotechnical Equipment and Components (IECEE System). All rights reserved.

This publication may be reproduced in whole or in part for non-commercial purposes as long as the IECEE is acknowledged as copyright owner and source of the material. IECEE takes no responsibility for and will not assume liability for damages resulting from the reader's interpretation of the reproduced material due to its placement and context.

If this Test Report Form is used by non-IECEE members, the IECEE/IEC logo and the reference to the CB Scheme procedure shall be removed.



This report is not valid as a CB Test Report unless signed by an approved CB Testing Laboratory and appended to a CB Test Certificate issued by an NCB in accordance with IECEE 02.

General disclaimer:

The test results presented in this report relate only to the object tested.

This report shall not be reproduced, except in full, without the written approval of the Issuing CB Testing Laboratory. The authenticity of this Test Report and its contents can be verified by contacting the NCB, responsible for this Test Report.

Test item description :	Rotary dimmer (Rotary dimmer RLC + LED)
Trade Mark :	
Manufacturer	Same as applicant
Model/Type reference :	CXM17; AG05476AA; AG06488AA; 617635; 617735; 617835 282419; 282419-C1; 282419-C2; 282419-C3; 282419-C; 833151, 832151, 731151
Ratings :	100-240 V; 50/60 Hz; Without contact gap; Integral type; IP20; 1) At 100-200 V rating voltage; 5-150 W for incandescent lamp; 5-150 VA for fluorescent Lamp; electronic step-down converter for extra low-voltage incandescent lamps (for example, halogen); Iron core transformer for extra low-voltage incandescent lamps (for example, halogen); 5-37 VA for self-ballasted fluorescent compact lamp (CFL) or self- ballast LED lamp; 2) At 200-240 V rating voltage; 5-300 W for incandescent lamp; 5-300 VA for fluorescent Lamp; electronic step-down converter for extra low-voltage incandescent lamps (for example, halogen); Iron core transformer for extra low-voltage incandescent lamps (for example, halogen); 5-75 VA for self-ballasted fluorescent compact lamp (CFL) or self- ballast LED lamp

Responsible Testing Laboratory (as applicable), testing procedure and testing location(s):		
<input checked="" type="checkbox"/>	CB Testing Laboratory:	Intertek Testing Services Shenzhen Ltd. Guangzhou Branch
Testing location/ address		Room 02, & 101/E201/E301/E401/E501/E601/E701/E801 of Room 01 1-8/F., No. 7-2. Caipin Road, Science City, GETDD, Guangzhou, Guangdong, China
Tested by (name, function, signature).....		Wells Fang/ Sr. Project Engineer 
Approved by (name, function, signature) ..		Shelley Ying/ Technical Manager 
<hr/>		
<input type="checkbox"/>	Testing procedure: CTF Stage 1:	
Testing location/ address		
Tested by (name, function, signature).....		--
Approved by (name, function, signature) ..		--
<hr/>		
<input type="checkbox"/>	Testing procedure: CTF Stage 2:	
Testing location/ address		
Tested by (name + signature).....		--
Witnessed by (name, function, signature) .		--
Approved by (name, function, signature) ..		--
<hr/>		
<input type="checkbox"/>	Testing procedure: CTF Stage 3:	
<input type="checkbox"/>	Testing procedure: CTF Stage 4:	
Testing location/ address		
Tested by (name, function, signature).....		--
Witnessed by (name, function, signature) .		--
Approved by (name, function, signature) ..		--
Supervised by (name, function, signature) :		--

List of Attachments (including a total number of pages in each attachment):

This report is totally 95 pages, page 1-81 is test report, and page 82-95 is product photos.

Summary of testing:

The submitted samples are also fulfilled the requirements of specified standard of:

- 1) IEC 60669-2-1: 2002 + AMD1: 2008 + AMD2: 2015 used in conjunction with IEC 60669-1:1998 + AMD1: 1999 + AMD2: 2006.
- 2) EN 60669-2-1: 2004 +A1: 2009+A12: 2010 used in conjunction with EN 60669-1: 1999 + AMD1: 2002 + AMD2: 2008.

Models covered by this report's relationship diagram:

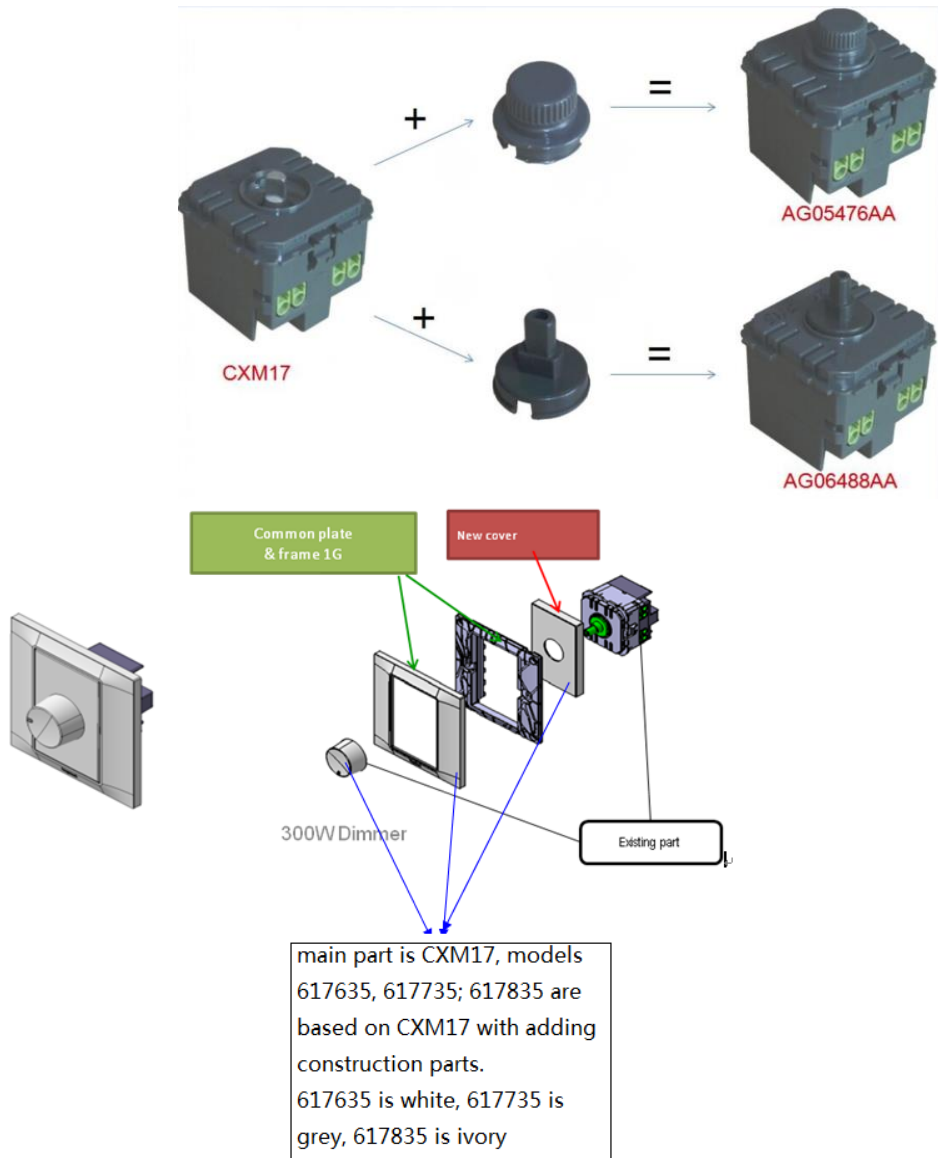

<p style="text-align: center;">AG06488AA + Frame + Cover 833151</p>	
<p>Tests performed (name of test and test clause): All applicable clauses</p>	<p>Testing location: Intertek Testing Services Shenzhen Ltd. Guangzhou Branch Room 02, & 101/E201/E301/E401/E501/E601/E701/E801 of Room 01 1-8/F., No. 7-2. Caipin Road, Science City, GETDD, Guangzhou, Guangdong, China</p>
<p>Summary of compliance with National Differences (List of countries addressed): EU.</p> <p><input checked="" type="checkbox"/> The product fulfils the requirements of <u>EN 60669-2-1: 2004 +A1: 2009+A12: 2010 used in conjunction with EN 60669-1: 1999 + AMD1: 2002 + AMD2: 2008.</u></p>	

Copy of marking plate:

The artwork below may be only a draft. The use of certification marks on a product must be authorized by the respective NCBs that own these marks.

Representative labels

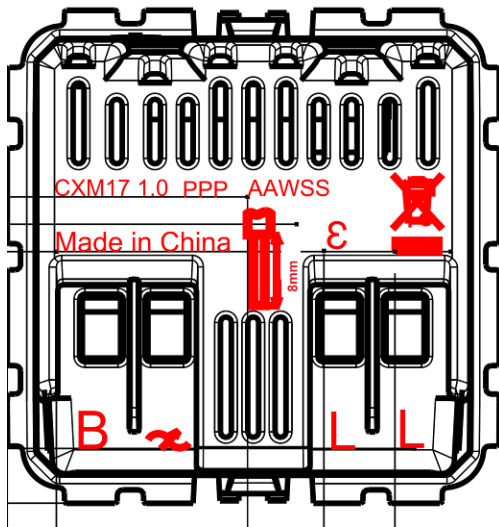
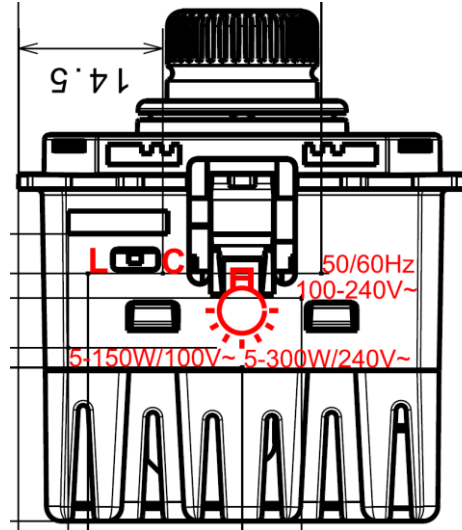
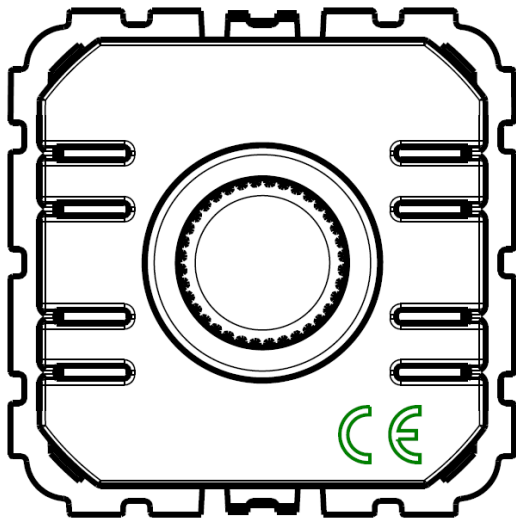

If the brand and the commercial reference needed, put it on the top of mechanism.
 Si on a besoin de marque et reference produit fini, ajouter en haut de méca.
 Készáru és márka jelzés felüntetése a termék tetején, ha szükséges.

AG05476AA and AG06488AA reference marking on the label.
 AG05476AA et AG06488AA reference marquage sur l'etiquette.
 AG05476AA és AG06488AA referencia felirat a címkén.

Location: printed on the external surface of dimmer integral enclosure

Test item particulars:

Type of electronic switch and its function (examples given in Annex AA)	Light dimmer with switch; Mechanically operated regulator with an electronic control circuit and a semiconductor switching device
Pattern number	1
Contact opening (gap) and switch performance	normal gap / mini-gap / micro-gap / <u>without contact gap (semiconductor switching device)</u>
Degree of protection against access to hazardous parts and against harmful effects due to the ingress of solid foreign objects	<u>IP2X</u> / IP4X / IP5X
Degree of protection against harmful effects due to the ingress of water	<u>IPX0</u> / IPX4 / IPX5
Method of actuating	<u>rotary</u> / tumbler / rocker / push-button / cord-operated / momentary contact / touch / proximity / optical / acoustic / Electronic RCS / Electronic TDS / other external influences
Method of mounting	surface-type / <u>flush-type</u> / semi flush-type / panel-type / architrave-type / height > 1,7 m
Method of installation	<u>design A</u> / design B
Type of terminals	<u>screw-type</u> / screwless (rigid) / screwless (rigid and flexible)
Flexible cable outlet	<u>without</u> / with
Rated current (A) / Rated load (VA or W)	1) At 100-200 V rating voltage; 5-150 W for incandescent lamp ; 5-150 VA for fluorescent Lamp; electronic step-down converter for extra low-voltage incandescent lamps (for example, halogen); Iron core transformer for extra low-voltage incandescent lamps (for example, halogen); 5-37 VA for self-ballasted fluorescent compact lamp (CFL) or self-ballast LED lamp; 2) At 200-240 V rating voltage; 5-300 W for incandescent lamp; 5-300 VA for fluorescent Lamp; electronic step-down converter for extra low-voltage incandescent lamps (for example, halogen); Iron core transformer for extra low-voltage incandescent lamps (for example, halogen); 5-75 VA for self-ballasted fluorescent compact lamp (CFL) or self-ballast LED lamp
Minimum current (A) / Minimum load (VA or W)	5 W or 5 VA
Kind of load controlled by the switch	<u>incandescent lamp / externally ballasted lamps: (e.g. fluorescent lamps, CFL, LED) / motors / self-ballasted lamps: (e.g. CFLi, LEDi) / declared load</u> / DLT controlled load
Type of switching mechanism	directly operated / sequentially operated / bistable / monostable (only for RCS) / <u>N/A</u>
Kind of energization of the control circuit	Electronic RCS energized by impulses / Electronics RCS permanently energized/ <u>N/A</u>

Type of control mechanism	mechanical / thermal / pneumatic / hydraulic / electrical / combination(s) of the previous (only TDS) / <u>N/A</u>
Rated control voltage (V)	a.c. / d.c. / <u>N/A</u>
Rated control current (A)	a.c. / d.c. / <u>N/A</u>
Rated voltage (V)	110 V / 120 V / 130 V / 220 V / 230 V / <u>100 V-240 V</u>
Rated frequency (Hz)	50 Hz / 60 Hz
Characteristic of fuses	Thermal link: 250 V; 5 A; 115°C
Electronics RCS or TDS having	SELV parts / PELV parts / <u>N/A</u>

Possible test case verdicts:

- test case does not apply to the test object : N/A
- test object does meet the requirement : P (Pass)
- test object does not meet the requirement : F (Fail)

Testing:

Date of receipt of test item : 19 November 2020
Date (s) of performance of tests : 19 November 2020 to 23 November 2020

General remarks:

The test results presented in this report relate only to the object tested.
This report shall not be reproduced, except in full, without the written approval of the Issuing testing laboratory.
"(see Enclosure #)" refers to additional information appended to the report.
"(see appended table)" refers to a table appended to the report.

Throughout this report a comma (point) is used as the decimal separator.
When determining for test conclusion, measurement uncertainty of tests has been considered.
This report is for the exclusive use of Intertek's Client and is provided pursuant to the agreement between Intertek and its Client. Intertek's responsibility and liability are limited to the terms and conditions of the agreement. Intertek assumes no liability to any party, other than to the Client in accordance with the agreement, for any loss, expense or damage occasioned by the use of this report. Only the Client is authorized to permit copying or distribution of this report and then only in its entirety. Any use of the Intertek name or one of its marks for the sale or advertisement of the tested material, product or service must first be approved in writing by Intertek. The observations and test results in this report are relevant only to the sample tested. This report by itself does not imply that the material, product, or service is or has ever been under an Intertek certification program.
The test report only allows to be revised only within the report defined retention period unless standard or regulation was withdrawn or invalid.
The clause which indicated with * is the subcontract test item.

Name and address of factory:

TCL-Legrand International Electrical (Huizhou) Co., Ltd.
Address: Bldg. B1-B3, East No.39 Hechang 6th Rd., HZZK Hi-tech Industrial Development Zone, Huizhou, Guangdong, China

General product information:

Products covered by this test report are rotary dimmer for integral type.
Model CXM17 should not be sold without suitable plastic cap wholly covered in metal rotary button.
All the models have same actuating member.



These products should be mounted in a supplement mounting box which is provided by factory and offered the protection against electric shock, the resistance to dust, solid objects and moisture. Detail of the supplement exemplified mounting box refers to standard sheet XV of CEE7.

Modification history:

Based on and superseded original report 190917153GZU-001 (dated on 25 November 2019):
--Added 3 models 833151, 832151, 731151. These models have same mechanical construction and electric circuit with original model 282419, only different Frame and Cover.

IEC 60669-2-1			
Clause	Requirement + Test	Result - Remark	Verdict

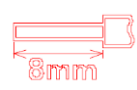
8	MARKING		P
8.1	Switches marked with:		P
	- rated voltage (V)	100-240 V	P
	- rated control voltage, if different from rated voltage (V)		N/A
	- rated current (A) or rated load (VA or W)	5-300 W for incandescent lamp/240 V~; 5-150 W for incandescent lamp/100 V~;	P
	- symbol for nature of supply	~	P
	- manufacturer's or responsible vendor's name, trade mark or identification mark		P
	- type reference	CXM17	P
	- symbol for mini-gap construction (m)		N/A
	- symbol for micro-gap construction (μ)		N/A
	- symbol for semiconductor switching device (ε)	ε	P
	- first IP characteristic numeral, if declared higher than 2, in which case the second characteristic numeral is also marked	IP2X	N/A
	- second IP characteristic numeral, if declared higher than 0, in which case the first characteristic numeral is also marked	IPX0	N/A
	- rated frequency (Hz)	50/60 Hz	P
	- rating and type of any fuse incorporated	Thermal link	N/A
	- symbol for kind of load (see 8.2)		P
	- the term "extension unit", if applicable, followed by the identifying reference		N/A
	- the minimum height for mounting the switch indicated in the installation instruction if there is a restriction (see 10.1)		N/A
	Switches with screwless terminals: marked with an indication of the suitability to accept rigid conductors only (if any)		N/A
	For electronic switches with included automatic function, number of operations shall be stated in the accompanying instruction sheet when number of operation is higher than the indicated in sub clause 19.101, 19.102 and 19.104 and 19.109		N/A
	- symbol for the adjustment of the delay time, if applicable		N/A
	- symbol for the positions "Permanent on" and "Permanent off", if applicable		N/A
	- symbol for "Delay time"		N/A

IEC 60669-2-1			
Clause	Requirement + Test	Result - Remark	Verdict
8.2	Symbols used: as required in the standard		P
	Marking for the nature of supply placed next to the marking for rated current and rated voltage	L; B; 	P
	Other particular symbols used are explained in the installation instructions		P
8.3	Marking of electronic switch placed on the main part:		P
	- rated current or rated load, rated voltage, symbol for nature of supply, rated frequency (if any), type of load, rating and type of any incorporated fuse (marked on the fuse-holder or in proximity of the fuse)		P
	- either the name, trade mark, or identification mark of the manufacturer or of the responsible vendor		P
	- length of insulation to be removed, if any		P
	- symbol for mini-gap construction, micro-gap construction or semiconductor switching device, if applicable		P
	- type reference		P
	Information concerning more than one type of load not already marked on the electronic switch are stated in the accompanying instruction sheet		P
	Minimum and maximum current/load are stated for each type of load		P
	Information of the iron core transformer intended to be used with the dimmer are given in the instruction sheet		P
	Cover plates necessary for safety purposes and intended to be sold separately: marked with the manufacturer's or responsible vendor's name, trade mark or identification mark and type reference		N/A
	IP code, when applicable, marked so as to be easily discernible when the switch is mounted and wired as in normal use		N/A
	Marking clearly visible and easily legible		P
	Markings are placed on parts which cannot be removed without the use of a tool		P
8.4	Terminals for phase conductors (supply conductors): identified unless method of connection is of no importance, self-evident or indicated on a wiring diagram		P
	Indications not placed on screws or other easily removable part		P

IEC 60669-2-1			
Clause	Requirement + Test	Result - Remark	Verdict
	Terminals associated with any one pole for switches of pattern number 2, 3, 03 and 6/2: similar identification differing from that of terminals associated with other poles		N/A
	Switches with more than two terminals: load terminal marked with an arrow pointing away from the terminal or with one of the symbol mentioned in 8.2		P
	Other terminals marked corresponding to the installation instructions		P
	Installation not made clear by the markings: a wiring diagram is provided with each electronic switch		P
	Terminals for the control circuit of a priority RCS with a current sensitive coil or voltage sensitive coil are marked with the appropriate symbol indicated in 8.2		N/A
	Terminals for the control circuit: marked according to IEC 60445 and/or with the symbols according to 8.2		N/A
8.5	Neutral terminals: N.....:		N/A
	Earthing terminals: [earth symbol]		N/A
	Markings not placed on screws or other easily removable parts		N/A
	Terminals for conductors not forming part of the main function of the switch:		N/A
	- clearly identified unless their purpose is self-evident, or		N/A
	- indicated in a wiring diagram fixed to the accessory		N/A
	Identification of equipment terminals may be achieved by:		N/A
	- their marking with graphical symbols according to IEC 60417 or colours and/or alphanumeric system, or		N/A
	- their physical dimension or relative location		N/A
8.6	Switches marked to indicate the switch position: they are so marked that the direction of movement of the actuating member to its different positions or the actual position is clearly indicated: See pictures		P
	Switches having more than one actuating member: marking indicates the effect achieved by the operation		N/A
	Marking clearly visible on the front of the switch		N/A
	Not possible to fix cover, cover plate, or removable actuating members in an incorrect position		P
	Symbols for "on" and "off" not used for indication of switch positions unless clearly indicate the direction of movement of the actuating members		N/A
	Off-state not marked with an "O" if the circuit on the		N/A

IEC 60669-2-1			
Clause	Requirement + Test	Result - Remark	Verdict

	load side is considered as live		
8.6.101	Actual state of electronic switches intended to control the brightness of lamps is indicated		N/A
	- marking on the on-/off-state position		N/A
	- indicator lamp		N/A
	- adjusting the lamp dimmer in the lowest control state and at rated voltage minus 10%: light still visible		N/A
	When the indication of the electronic switch state is given only by the lamp, adjustment of the lamp at the lowest control state is made as specified in the following:		N/A
	- for incandescent lamps:		N/A
	the adjustment of lamp dimmers is made by the manufacturer		N/A
	not possible to reduce the lowest setting without a tool		N/A
	- for fluorescent lamps:		N/A
	the adjustment of lamp dimmers is made by the manufacturer		N/A
	it is possible for the installer to alter the lowest setting if indicated in an installation instruction		N/A
8.7	Red colour only for push-button to open the circuit		N/A
8.8	Special precautions necessary to take when installing the switch: details of these and clear information given in an instruction sheet which accompanies the switch		N/A
	Electronic switch containing a viewing window (lens) intended to be mounted at a height greater 1.7 m: information stated in the instruction sheet		N/A
8.9	Marking durable and easily legible. Test: 15 s with water and 15 s with petroleum spirit		P

9	CHECKING OF DIMENSIONS		P
	Switches and boxes comply with the appropriate standard sheets, if any		N/A
	Electronic switches with dimensions other than those specified in the standard sheets (if any) if they are supplied with suitable boxes	Integral type, and should be mounted in a supplement mounting box which is provided by factory and offered the protection against electric shock , the resistance to dust, solid objects and moisture.	P

10	PROTECTION AGAINST ELECTRIC SHOCK		P
-----------	--	--	----------

IEC 60669-2-1			
Clause	Requirement + Test	Result - Remark	Verdict
10.1	Switches: live parts not accessible	Integral type, and should be mounted in a supplement mounting box which is provided by factory and offered the protection against electric shock , the resistance to dust, solid objects and moisture. Model CXM17 should not be sold without suitable plastic cap wholly covered in metal rotary button.	P
	Switches designed to be fitted with pilot lights supplied at voltages other than ELV have means to prevent direct contact with the lamp		N/A
	Test with standard test finger shown in figure 1 of IEC 60529		P
	Switches with thermoplastic or elastomeric material: additional test carried out at 35 °C ± 2 °C with the test probe 11 of IEC 61032 (75 N for 1 min)		P
	Test probe applied to:		P
	- thin-walled knock-outs with a force of 10 N		P
	- viewing windows or the like on electronic switches intended to be mounted at a height > 1,7 m with a force of 30 N		P
	During the test: switches not deform and no live parts accessible		P
10.2	Knobs, operating levers, push buttons, rockers and the like: of insulating material, unless:	load adjusted plastic digital switch	N/A
	- accessible metal parts separated from metal parts of mechanism by double or reinforced insulation, or		N/A
	- reliably connected to earth		N/A
	For touch sensitive electronic switches the associated protective impedance does not have to comply with the requirements of clauses 16 and 23		N/A
	Accessible parts (for example, sensing surface) of electronic switches with IPX0 are connected to live parts by means of a protective impedance that:		N/A
	- consists of at least two independent resistors or independent capacitors in series of the same nominal value, or a combination of both		N/A
	- resistors comply with 102.3		N/A
	- capacitors comply with 102.2		N/A
	The removal of protective impedance is only possible by destruction of the electronic switch or by rendering it unusable		N/A

IEC 60669-2-1			
Clause	Requirement + Test	Result - Remark	Verdict
	Test carried out between accessible metal parts and earth, through a non-inductive resistor of 2 kΩ:		N/A
	current measured: ≤ 0,7 mA (peak value), for a.c. up to 1 kHz		N/A
	current measured: ≤ 0,7 mA multiplied by the value of frequency in kHz, but not exceed 70 mA, for a.c. above 1 kHz		N/A
	current measured: ≤ 2 mA, for d.c.		N/A
10.3	Accessible parts of switches with $I_n \leq 16$ A: made of insulating material		P
10.3.1	Metal covers or cover plates protected by supplementary insulation made by insulating linings or insulating barriers		N/A
	Insulating linings or insulating barriers:		N/A
	- cannot be removed without being permanently damaged, or designed that		N/A
	- cannot be replaced in an incorrect position; if they are omitted, accessories are rendered inoperable or manifestly incomplete; there is no risk of accidental contact between live parts and metal covers or cover plates; precautions are taken to prevent creepage distances or clearances becoming less than the values specified in clause 23		N/A
10.3.2	Earthing of metal covers or cover plates: connection of low resistance		N/A
10.4	Metal parts of mechanism not insulated from live parts: not protrude from enclosure		N/A
	Switches operated by means of a removable key or similar device: metal parts of mechanism insulated from live parts		N/A
10.5	Metal parts of mechanism not accessible and insulated from accessible metal parts, unless		N/A
	- separated from live parts (creepage distances and clearances have at least twice the value specified in clause 23), or		N/A
	- reliably connected to earth		N/A
10.6	Switches operated by means of a removable key or an intermediate part: key or an intermediate part can only touch parts insulated from live parts		N/A
	key or intermediate part: insulated from metal parts of mechanism, unless		N/A
	creepage distances and clearances between live parts and metal parts of mechanism have at least twice the values specified in clause 23		N/A
10.7	Cord-operated switches: impossible to touch live parts when fitting or replacing the pull cord		N/A

IEC 60669-2-1			
Clause	Requirement + Test	Result - Remark	Verdict
10.101	If a cover or cover-plate or a fuse can be removed without a tool or if the installation instructions for the user indicate that, for the purpose of maintenance, when replacing the fuse, covers and cover plates fastened by means of a tool have to be removed, the protection against contact with live parts is assured even after removal of cover or cover-plate (this requirement does not apply when the electronic switch must be dismantled from its supporting means for the replacement of the fuse-link)		P
	Compliance is checked with the test probe B of IEC 61032 (10 N); test probe does not touch live parts		P
10.102	Hole in electronic switches for adjusting the setting:		P
	The adjustment does not involve the risk of an electric shock		P
	Compliance is checked by applying a test pin according to figure 101 through the hole; test pin does not touch live parts		P
10.103	Ventilation openings over live parts:		N/A
	A foreign body introduced into these openings do not come into contact with any live parts		N/A
	Compliance is checked by applying the test probe 13 of IEC 61032 through the openings; pin of test probe does not touch live parts		N/A

11	PROVISION FOR EARTHING		N/A
	Clause not applicable to SELV electronic switches		N/A
11.1	Accessible metal parts: provided with, or permanently and reliably connected to, an earthing terminal		N/A
11.2	Earthing terminals: with screw clamping or screwless terminals and comply with clause 12		N/A
	Capacity of earthing terminals of the same size as the corresponding terminals for the supply conductors		N/A
	Any additional external earthing terminal has a size suitable for conductors of at least 6 mm ² (mm ²):		N/A
11.3	Surface-type switches with an enclosure of insulating material, with IP > X0 and more than one cable inlet, are provided for the continuity of the earthing circuit with:		N/A
	- an internal fixed earthing terminal, or		N/A
	- adequate space for a floating terminal allowing the connection of an incoming and outgoing conductor		N/A
11.4	Connection between earthing terminal and accessible metal parts: of low resistance		N/A

IEC 60669-2-1			
Clause	Requirement + Test	Result - Remark	Verdict

	Test current equal to 1,5 In or 25 A (A)		—
	Resistance $\leq 0,05 \Omega$ (Ω)		N/A
11.101	Printed circuit of printed circuit boards board may be used to provide protective earthing continuity if:		N/A
	- at least two tracks with independent soldering points which withstand a single short circuit test similar to 101.3 and immediately after the switch shall fulfil the requirements of 11.4, or		N/A
	- a single track is used with two independent means of connection on each end which will withstand a single short circuit test similar to 101.3 and immediately after the switch shall fulfil the requirements of 11.4,		N/A
	In addition:		N/A
	- the laminated of the printed circuit board shall consist of epoxide glass fabric copper-clad laminated sheet, and		N/A
	- the printed circuit boards shall comply with the overload test of 101.1.1.2.		N/A

12	TERMINALS		P
12.1	General		P
	Switches provided with screw-type terminals or with screwless terminals	Screw terminal block (1,0~2,5 mm ²)	P
	Clamping means of terminals: not serve to fix any other components		P
	All the test on terminals, with the exception of the test of 12.3 11, made after the test of 15.1		P
	Terminals having screw clamping complying with IEC 60998-2-1 are considered to be in compliance with the requirements and the tests of Subclause 12.2, except those of 12.2.6 and 12.2.7 and 12.2.8, provided they are chosen according Table 2.		P
12.2	Terminals with screw clamping for external copper conductors		P
12.2.1	Switches provided with terminals which allows the proper connection of copper conductors as shows in table 2	Pillar terminals	P
	Rated current (A)	1,5 A < 4 A	—
	Type of conductor (rigid / flexible)	rigid / flexible	—
	Smallest / largest cross-sectional area (mm ²)	Not required by standard; 1,0~2,5 mm ² in user manual	—
	Diameter of largest conductor (mm)	Not required by standard;	—
	Figure of terminal	1 / 2 / 3 / 4 / 5	—

IEC 60669-2-1			
Clause	Requirement + Test	Result - Remark	Verdict
	Minimum diameter D (minimum dimensions) of conductor space: required (mm); measured (mm) ...:	Required: min. 3,0 mm; Measured: 3,4 mm	P
12.2.2	Terminals allow the conductor to be connected without special preparation		P
12.2.3	Terminals have adequate mechanical strength		P
	Screws and nut for clamping the conductors have metric ISO thread or a comparable thread		P
	Screws not of soft metal such as zinc or aluminium		P
12.2.4	Terminals resistant to corrosion		P
12.2.5	Screw-type terminals clamp the conductor(s) without undue damage	See appended table 12.2.5	P
	During the test: conductor not slip out, no break near clamping unit and no damage		P
12.2.6	Terminals clamp the conductor reliably between metal surfaces	See appended table 12.2.6	P
	During the test: conductor not move noticeably		P
12.2.7	Terminals designed or placed that the conductor cannot slip out while the clamping screws or nuts are tightened	See appended table 12.2.7	P
	After the test: no wire of the conductor escaped outside the clamping unit thus reducing creepage distances and clearances to values lower than those indicated in clause 23		P
12.2.8	Terminals not work loose from their fixing to the switch		P
	Torque test:		P
	- rated current (A)	1,5 A	—
	- solid rigid copper conductor of the largest cross-sectional area (mm ²) (table 2)	Not required by standard; 2,5 mm ² in user manual	—
	- torque (Nm) (table 3 or appropriate figures 1, 2, 3, 4)	0,5 Nm	—
	Screws and nuts tightened and loosened 5 times. During the test: terminals not work loose and show no damage		P
12.2.9	Clamping screws or nuts of earthing terminals: adequately locked against accidental loosening, not possible to loosen them without the aid of a tool		N/A
12.2.10	Earthing terminals: no risk of corrosion		N/A
	Body of brass or other metal no less resistant to corrosion		N/A
	If the body is a part of a frame or enclosure of aluminium alloy, precautions are taken to avoid the risk of corrosion		N/A

IEC 60669-2-1			
Clause	Requirement + Test	Result - Remark	Verdict
12.2.11	Pillar terminals: distance g no less than the value specified in figure 1: required (mm); measured (mm)		N/A
	Mantle terminals: distance g no less than the value specified in figure 5: required (mm); measured (mm)		N/A
12.2.12	Lug terminals:		N/A
	- used only for switches having rated current ≥ 40 A		N/A
	- fitted with spring washers or equally effective locking means		N/A
12.3	Screwless terminals for external copper conductors		N/A
12.3.1	Screwless terminals of the type suitable for:		N/A
	- for rigid copper conductors only, or		N/A
	- for both rigid and flexible copper conductors (tests carried out with rigid and then repeated with flexible conductors)		N/A
12.3.2	Screwless terminals provided with clamping units which allow the proper connection of rigid or of rigid and flexible conductors having nominal cross-sectional areas as shown in table 7		N/A
	Rated current (A)		—
	Type of conductor (rigid / flexible)		—
	Smallest / largest cross-sectional area (mm ²)		—
	Diameter of largest rigid conductor (mm)		—
	Diameter of largest flexible conductor (mm)		—
12.3.3	Screwless terminals allow the conductor to be connected without special preparation		N/A
12.3.4	Parts of screwless terminals intended for carrying current of materials as specified in 22.5		N/A
12.3.5	Screwless terminals clamp specified conductors with sufficient contact pressure without undue damage to the conductor		N/A
	Conductor clamped between metal surfaces		N/A
12.3.6	It is clear how the connection and disconnection of the conductors is to be made		N/A
	Disconnection of a conductor require an operation, other than a pull, so that can be made manually with or without a general-purpose tool		N/A
	It is not possible to confuse the opening for the use of a tool with the opening intended for the conductor		N/A
12.3.7	Screwless terminals intended for the interconnection of two or more conductors:		N/A

IEC 60669-2-1			
Clause	Requirement + Test	Result - Remark	Verdict
	- during insertion, operation of clamping means of one of the conductors is independent of operation of that for the other conductor(s);		N/A
	- during disconnection, conductors can be disconnected either at the same time or separately;		N/A
	- each conductor introduced in a separate clamping unit.		N/A
	It is possible clamp securely any number of conductors up to the maximum as designed. Number of conductors; Nominal cross-sectional area (mm ²)		N/A
12.3.8	Screwless terminals: adequate insertion obvious and over-insertion prevented		N/A
	Screwless terminals of switches: undue insertion of the conductor prevented by a stop if further insertion is liable to reduce creepage distances and/or clearances required in table 20 or to influence the mechanism		N/A
12.3.9	Screwless terminals properly fixed to the switch		N/A
	Not work loose when conductors are connected or disconnected		N/A
	Self-hardening resins used to fix terminals not subject to mechanical stress		N/A
12.3.10	Screwless terminals withstand mechanical stresses occurring in normal use	See appended table 12.3.10	N/A
	During application of the pull conductor not come out of the terminal		N/A
	Test with apparatus shown in figure 10	See appended table 12.3.10	N/A
	During the test conductors not move noticeably in the clamping unit		N/A
	After these tests: neither terminals nor clamping means have worked loose and conductors show no deterioration		N/A
12.3.11	Screwless terminals withstand electrical and thermal stresses occurring in normal use	See appended table 12.3.11	N/A
	After the test: inspection show no changes		N/A
	Repetition of test according to 12.3.10: screwless terminals withstand mechanical stresses occurring in normal use	See appended table 12.3.11	N/A
	During application of the pull conductor not come out of the terminal		N/A
	Test with apparatus shown in figure 10	See appended table 12.3.11	N/A
	During the test conductors not move noticeably in the clamping unit		N/A

IEC 60669-2-1			
Clause	Requirement + Test	Result - Remark	Verdict

	After these tests: neither terminals nor clamping means have worked loose and conductors show no deterioration		N/A
12.3.12	Screwless terminals: connected rigid solid conductor remains clamped, even when deflected during normal installation	See appended table 12.3.12	N/A

13	CONSTRUCTIONAL REQUIREMENTS		P
13.1	Insulating lining, barriers and like: adequate mechanical strength and secured in a reliable manner	Integral type, and should be mounted in a supplement mounting box which is provided by factory and offered the protection against electric shock , the resistance to dust, solid objects and moisture.	P
13.2	Switches constructed so as to permit:		P
	- easy introduction and connection of the conductors in the terminals;		P
	- correct positioning of the conductors		P
	- easy fixing of the switch to a wall or in a box		P
	- adequate space between underside of the base and the surface on which the base is mounted or between the sides of the base and the enclosure (cover or box)		P
	Surface-type switches: fixing means do not damage insulation of the cable		N/A
	Switches classified as design A: permit easy positioning and removal of the cover or cover plate, without displacing the conductors		P
13.3	Covers, cover-plates and actuating members or parts of them intended to ensure protection against electric shock:		P
	- held in place at two or more points by effective fixings		P
	- fixed by means of a single fixing, for example by a screw, provided that they are located by another means (for example by a shoulder)		N/A
	Fixings of covers, cover-plates or actuating members of switches of design A serves to fix the base: there is means to maintain the base in position, even after removal of the covers, cover-plates or actuating members		P
13.3.1	Covers, cover plates or actuating members whose fixing is of the screw-type:		N/A
	Compliance checked by inspection only		N/A
13.3.2	Covers, cover plates or actuating members whose fixing is not dependent on screws and whose removal is obtained by applying a force in a direction approximately perpendicular to the mounting/supporting surface:		N/A

IEC 60669-2-1			
Clause	Requirement + Test	Result - Remark	Verdict
	Compliance checked, when their removal may give access, with the standard test finger:		N/A
	to live parts: by the test of 20.4 (verification of the non-removal and the removal)		N/A
	to non-earthed metal parts separated from live parts by creepage distances and clearances according to table 20: by the test of 20.5 (verification of the non-removal and the removal)		N/A
	only to insulating parts, or earthed metal parts, or metal parts separated from live parts by creepage distances and clearances twice those according to table 20, or live parts of SELV circuits not greater than 25 V a.c.: by the test of 20.6 (verification of the non-removal and the removal)		N/A
13.3.3	Covers, cover-plates or actuating members whose fixing is not dependent on screws and whose removal is obtained by using a tool, in accordance with the manufacturer's information given in an instruction sheet or in a catalogue:		P
	Compliance checked, when their removal may give access, with the standard test finger:		P
	to live parts: by the test of 20.4 (verification of the non-removal only)		N/A
	to non-earthed metal parts separated from live parts by creepage distances and clearances according to table 20: by the test of 20.5 (verification of the non-removal only)		P
	only to insulating parts, or earthed metal parts, or metal parts separated from live parts by creepage distances and clearances twice those according to table 20, or live parts of SELV circuits not greater than 25 V a.c.: by the test of 20.6 (verification of the non-removal only)		P
13.4	Switches: no free openings in their enclosures according to their IP classification		P
	Free openings according to 10.102 and 10.103 are accepted		N/A
13.5	Knobs of electronic switches are securely fixed in a reliable manner		P
	knobs used to indicate the position of switches: not possible to fix them in a wrong position, if this may result in a hazard		P
	Pull and push tests:		P
	- axial pull is likely to be applied: 30 N for 1 min		N/A
	- axial pull is unlikely to be applied: 15 N for 1 min		P
	- axial push: 30 N for 1 min		P
	During and after these tests:		P
	- the electronic switch shows no damage		P

IEC 60669-2-1			
Clause	Requirement + Test	Result - Remark	Verdict
	- an knob have not moved so as to impair compliance with this standard		P
13.6	Screws or other means for mounting the switch on a surface or in a box or enclosure: easily accessible from the front.		P
	Fixing means not serve any other fixing purpose		P
13.7	Combinations of switches, or of switches and socket-outlets, comprising separate bases: correct position of each base ensured		N/A
	Fixing of each base independent of the fixing of the combination to the mounting surface		N/A
13.8	Accessories combined with switches: comply with their standard		N/A
13.9	Surface-type switches with IP > 20 are in according to their classification when fitted with conduits or with sheathed cables		N/A
	Surface-type switches with IPX4 or IPX5 have provisions for opening a drain hole		N/A
	Switches provided with a drain hole: it is not less than 5 mm in diameter, or 20 mm ² in area with a width and a length not less than 3 mm: Ø mm / mm ²		N/A
	Drain hole: effective		N/A
	Lid springs (if any): of corrosion resistant material (bronze or stainless steel)		N/A
13.10	Switches to be installed in a box: conductor ends can be prepared after the box is mounted in position, but before the switch is fitted in the box		P
	Base have adequate stability when mounted in the box		P
13.11	Surface-type switches with IP > X0, pattern numbers 1, 5 and 6, with more than one inlet opening, provided with:		N/A
	- fixed additional terminal complying with the requirements of clause 12, or		N/A
	- adequate space for a floating terminal		N/A
13.12	Inlet openings: allow the introduction of the conduit or the sheath of the cable		N/A
	Surface-type switches: intended conduit or protective covering can enter at least 1 mm into the enclosure		N/A
	Inlet openings for conduit entries of surface-type switches: capable of accepting conduit sizes of 16, 20, 25 or 32 or a combination of at least two of these sizes not excluding two of the same size:		N/A

IEC 60669-2-1			
Clause	Requirement + Test	Result - Remark	Verdict
	Inlet openings for cable entries of surface-type switches: capable of accepting cables having the dimensions specified in table 12 or be as specified by the manufacturer: rated current (A); limits of external diameter of cables min/max (mm)		N/A
13.13	Surface-type switches: provision for back entry (if are intended)		N/A
13.14	Membranes or the like (if provided): replaceable		N/A
13.15	Requirements for membranes in inlet openings		N/A
13.15.1	Membranes, lenses and the like reliably fixed and not displaced by the mechanical and thermal stresses occurring in normal use		N/A
	Test on electronic switches fitted with membranes, lenses and the like subjected to the ageing treatment specified in 15.1:		N/A
	Electronic switches placed at 40 °C ± 2 °C for 2 h; force of 30 N applied for 5 s by means of the tip of test probe 11 of IEC 61032. During these tests: membranes, lenses and the like are not deformed, live parts not accessible		N/A
	Membranes, lenses and the like likely to be subjected to an axial pull: axial pull of 30 N applied for 5 s. During this test: membranes, lenses and the like not come out		N/A
	Test repeated on membranes, lenses and the like not subjected to any treatment		N/A
13.15.2	Membranes in inlet openings: introduction of the cables into the accessory permitted when the ambient temperature is low		N/A
	Test on membranes not subjected to the ageing treatment specified in 15.1 and fitted with the switches		N/A
	Switches kept at -5 °C for 2 h: possibility to introduce cables of the heaviest type through the membranes		N/A
	After the test: no harmful deformation, cracks or similar damage		N/A
13.16	Flexible cable outlet switches: flexible cable (60245 IEC 66 or 60227 IEC 53, or as specified by the manufacturer) may enter the switch through a suitable hole, groove or gland		N/A
	Maximum dimension of flexible cable having conductors specified in table B.1 accepted by the entry:		N/A
	- rated current (A)		—
	- cross-sectional area (mm ²) (min 1,5 mm ²)		—
	Entry shaped to prevent damage to the flexible cable		N/A

IEC 60669-2-1			
Clause	Requirement + Test	Result - Remark	Verdict
	Switches intended to be connected via a flexible cable to an electronic extension unit having a rated current equal to the rated current of the electronic switch: flexible cable complies with 60245 IEC 66 or 60227 IEC 53 with a minimum cross sectional area of 0,75 mm ²		N/A
	Switches intended to be connected via a flexible cable to an electronic extension unit having a rated current lower than the rated current of the electronic switch: flexible cable complies with the requirements of 13.103		N/A
	Switches with flexible cable outlet: provided with cable anchorage		N/A
	Cable anchorage: contains the sheath, of insulating material or provided with an insulating lining fixed to the metal parts		N/A
	Cable anchorage: anchor the flexible cable securely to the switch		N/A
	Cable anchorage cannot be released from the outside		N/A
	Use of a special purpose tool not required		N/A
	Screws: not serve to fix any other component, unless		N/A
	- switch is rendered manifestly incomplete if component omitted or replaced in an incorrect position, or		N/A
	- component cannot be removed without further use of a tool		N/A
	Pull test (30 N, 25 times): cable 60227 IEC 53, cross-sectional area 1,5 mm ² ; torque (Nm) (2/3 table 3)		N/A
	Torque test: torque 0,15 Nm for 1 min, cable not displaced > 2 mm		N/A
	Pull test (60 N, 25 times): cable 60245 IEC 66, diameter (mm) of cable; torque (Nm) (2/3 table 3) ...		N/A
	Torque test: torque 0,35 Nm for 1 min, cable not displaced > 2 mm		N/A
	Test voltage of 2000 V a.c. applied for 1 min between the conductors and the cord anchorage:		N/A
	During the test: insulation of flexible cable not damaged (no breakdown or flashover)		N/A
13.101	Cut-outs in electronic switches for motor speed control circuits: non-self-resetting		N/A
13.102	Electronic switches for the control of the voltage of iron core transformers for extra low-voltage incandescent lamps (for example, halogen): maximum tolerance of the phase-control angle		N/A

IEC 60669-2-1			
Clause	Requirement + Test	Result - Remark	Verdict

	between the positive and negative half-wave of $\pm 2^\circ$:		
13.103	TDS shall be of the resetting type		N/A

14	MECHANISM		N/A
	Clause only applicable to electronic switches provided with mechanical switching devices		N/A
14.1	Actuating member of a switch, when released, automatically take up the position corresponding to that of moving contacts		N/A
14.2	Moving contact of switches can come to rest only in "on" and "off" positions		N/A
	Intermediate position permissible if:		N/A
	- it corresponds to the intermediate position of the actuating member, and		N/A
	- the insulation between fixed and moving contacts is adequate. Electric strength test as specified in 16.2: test voltage a.c. for 1 min (V)	500 V / 750 V / 1250 V / 2000 V	N/A
14.3	No undue arcing in slowly operation		N/A
	Test carried out at the end of the test of clause 19.1: breaking of the circuit 10 times, actuating member moved over a period of 2 s. During the test: no sustained arcing		N/A
14.4	Switches of pattern numbers 2, 3, 03 and 6/2 make and break all poles substantially simultaneously		N/A
	Neutral pole of switches of pattern numbers 03 not make after or break before the other poles		N/A
14.5	Action of the mechanism: independent of the presence of cover or cover plate. Test: no flicker		N/A
14.6	Cord-operated switches: effecting a change by application and removal a pull not exceeding:		N/A
	- 45 N applied vertically, and		N/A
	- 65 N applied at $45^\circ \pm 5^\circ$		N/A
14.101	Position indicator used in RCS equipped with an incorporated hand-operated device indicates the position of the switching circuit clearly and without ambiguity		N/A
	TDS equipped with an incorporated hand-operated device and a position indicator is used indicates the position of the switching circuit clearly and without ambiguity		N/A

15	RESISTANCE TO AGEING, PROTECTION PROVIDED BY ENCLOSURES OF SWITCHES, AND RESISTANCE TO HUMIDITY		P
15.1	Resistance to ageing		P

IEC 60669-2-1			
Clause	Requirement + Test	Result - Remark	Verdict
	Switches and boxes placed for 7 days (168 h) in a heating cabinet at 70 °C ± 2 °C		P
	- no crack visible after test with normal or corrected vision without additional magnification		P
	- no sticky or greasy material as a result of heat		P
	- no trace of cloth (forefinger pressed with 5 N)		P
	- no other damage as a result of heat		P
15.2	Protection provided by enclosures of switches		P
15.2.1	Protection against access to hazardous parts and against harmful effects due to ingress of solid foreign objects		P
	Enclosure of the switch provides a degree of protection against access to hazardous parts and against harmful effects due to ingress of solid foreign objects in accordance with the IP classification of the switch		P
	Glands: torque (Nm) (2/3 of torque applied in 20.3) :		—
	Screws of the enclosure: torque (Nm) (2/3 table 3)		—
15.2.1.1	Protection against access to hazardous parts		P
	Appropriate test according to IEC 60529: IP20		P
15.2.1.2	Protection against harmful effects due to ingress of solid foreign objects		P
	Appropriate test according to IEC 60529: IP20		P
	Dust not penetrate in quantity to interfere with satisfactory operation or to impair safety		P
15.2.2	Protection against harmful effects due to ingress of water		N/A
	Enclosure of switches provide a degree of protection against harmful effects due to ingress of water in accordance with their IP classification		N/A
	Appropriate test according to IEC 60529: IP		N/A
	Flush-type and semi-flush-type switches fixed:		N/A
	- in a test wall using an appropriate box in accordance with the manufacturer's instructions		N/A
	- in a test wall according to figure 27		N/A
	Screws of the enclosure: torque (Nm) (2/3 table 3)		—
	Glands: torque (Nm) (2/3 of torque applied in table 19)		—
	Specimens withstand an electric strength test specified in 16.2 which is started within 5 min of completion of the test		N/A
15.3	Resistance to humidity		P
	Switches proof against humidity which may occur in normal use		P

IEC 60669-2-1			
Clause	Requirement + Test	Result - Remark	Verdict

	Compliance checked by a humidity treatment carried out in a humidity cabinet containing air with relative humidity maintained between 91 % and 95 %. Specimens kept in the cabinet for:		P
	- 2 days (48 h) for switches with IPX0	IP20	P
	- 7 days (168 h) for switches with IP>X0		N/A
	After this treatment: specimens show no damage		P

16	INSULATION RESISTANCE AND ELECTRIC STRENGTH		P
16.1	The insulation resistance measured 1 min after application of 500 V d.c.	See appended table 16.1	P
16.2	Electric strength: a.c. test voltage applied for 1 min	See appended table 16.2	P

17	TEMPERATURE RISE		P
17.1	Switches so constructed that the temperature rise in normal use is not excessive		P
	No oxidation or any other deterioration of contacts, if any		N/A
	Material and components of electronic switch are not adversely effected by the temperature rise in normal use		P
	During the test:		P
	- electronic switch state not change		P
	- fuses and other protective devices not operate		P
	- permissible temperature rises determined in table 102, column concerning clause 17, not exceeded	See appended table 17	P
	After the test, electronic switch is in operating condition		P
	Sealing compounds, if any, have not flowed		N/A

18	MAKING AND BREAKING CAPACITY		N/A
	Electronic switches have adequate making and breaking capacity		N/A
	Test carried out only on electronic switches provided with mechanically or electromechanically operated contact mechanisms		N/A
	Contact mechanisms have adequate making and breaking capacity		N/A
	Test made on three new specimens of the complete contact mechanism		N/A
	Model/type reference		—
	Pattern number		—

IEC 60669-2-1			
Clause	Requirement + Test	Result - Remark	Verdict
	Rated current (A) / Rated load (W or VA)		—
	Rated voltage (V)		—
	Test for electronics switches for the control of:		N/A
	- fluorescent lamp loads, as specified in 18.1 of part 1;		N/A
	- motor speed control circuits, as specified in 18.1 of part 1 and, additionally, in 18.101;		N/A
	- voltage of iron core transformers for extra low-voltage incandescent lamps, as specified in 18.1, 18.2 of part 1 and, additionally, in 18.102;		N/A
	- voltage of electronic step-down converters for extra low-voltage incandescent lamps, as specified in 18.2 of part 1;		N/A
	- other types of load, as specified in 18.1 and 18.2 of part 1.		N/A
	- self ballasted lamps, as specified in 18.1 of part 1.		N/A
	Rate of operation (operation per minute)		—
	Electronic switches whose cycle of operation limited by their application: rate of operation specified by the manufacturer (operation per minute)		—
	Electronic switches fitted with conductors having nominal cross-sectional area as for the test of clause 17 (mm ²)		—
18.1	Test with cos φ 0,3 alternating current		N/A
	- test voltage (1,1 V _n) (V)		—
	- test current (1,25 I _n) (cos φ 0,3) (A)		—
	- 200 operations; rate (operations per minute)		—
	- electronic switches whose rate of operation is limited by their application (for example, heat and light sensors): electronic switch is set to the shortest cycle time possible and re-activated at the end of each cycle within a time of (2 ± 0,5) s		—
	- samples number		—
	During the test: no sustained arcing		N/A
	After the test: specimens show no damage		N/A
	Test with cos φ 0,3 alternating current for electronics TDS		N/A
	- test voltage (1,1 V _n) (V)		—
	- test current (1,25 I _n) (cos φ 0,3) (A)		—
	- 200 operations; rate (operations per minute)		—
	- electronic TDS whose rate of operation is limited by their application (for example, heat and light sensors): electronic TDS is set to the shortest cycle		—

IEC 60669-2-1			
Clause	Requirement + Test	Result - Remark	Verdict

	time possible and re-activated at the end of each cycle within a time of $(2 \pm 0,5)$ s		
	- samples number		—
	During the test: no sustained arcing		N/A
	After the test: specimens show no damage		N/A
18.2	Test with tungsten filament lamps load (switches with $I_n \leq 16$ A / $V_n \leq 250$ V and switches of pattern numbers 3 and 03 with $V_n > 250$ V)		N/A
	- test voltage (V_n) (V)		—
	- test current ($\geq 1,2 I_n$) (A)		—
	- number of 200 W tungsten filament lamps		—
	- 200 operations; rate (operations per minute)		—
	- samples number		—
	During the test: no sustained arcing nor welding of the contacts		N/A
	After the test: specimens show no damage		N/A
18.101	Additional test for electronic switches for the control of motor speed control circuits:		N/A
	Rated current I_n (A) of electronic switch ($\cos\phi$ 0.6) :		—
	Making: 50 cycles with: test current: $9 I_n$ (A); test voltage: V_n (V); $\cos\phi$ 0.8 ± 0.05		N/A
	Breaking: 50 cycles with: test current: $6 I_n$ (A); test voltage: V_n (V); $\cos\phi$ 0.6 ± 0.05		N/A
	During the test: no sustained arcing		N/A
	After the test: specimens show no damage		N/A
18.102	Additional test for electronic switches for the control of the voltage of iron core transformers for extra low-voltage incandescent lamps (for example, halogen):		N/A
	- test voltage (V_n) (V)		—
	- 50 making operations in a test circuit adjusted to a test current 10 times I_n (A) for one half-cycle of the power supply frequency		—
	During the test: no sustained arcing		N/A
	After the test: specimens show no damage		N/A

19	NORMAL OPERATION		P
	Electronic switches withstand the mechanical, electrical and thermal stresses occurring in normal use		P
	Electronic switches whose cycle of operation is limited by their application: rate of operation specified by the manufacturer (operation per minute)	6 s per cycle.	—
	For electronic switches with included automatic		—

IEC 60669-2-1			
Clause	Requirement + Test	Result - Remark	Verdict
	function the number of operations for tests of subclauses 19.101, 19.102 19.104 and 19.109 is that specified in the relevant subclause.		
	If a manufacturer declares a number of operation higher than those indicated in the relevant subclause, the tests shall be made according to declared value.		—
	Sticking of the contacts, which does not prevent the next operation, is not considered as welding.		N/A
	Sticking of the contacts is permitted if the contacts can be separated with a force applied to the actuator of a value which does not damage the switch mechanically		N/A
	Electronic switches including electronic circuits which close the contact of the contact mechanism always at zero-crossing $\pm 20^\circ$ phase angle, shall be tested together with their electronic circuit		N/A
	Electronic RCS withstand without excessive wear or other harmful effect, the mechanical, electrical and thermal stresses occurring in normal use		N/A
	- model/type reference		—
	- pattern number		—
	- nominal cross-sectional area per clause 18 (mm ²)		—
	- test voltage (Vn) (V)		—
	- test current (In) (cos ϕ 0,6) (A)		—
	- number of operations per table 17		—
	- rate (operations per minute)		—
	- samples number		—
	Reduced electric strength per clause 16	See appended table 19.1	N/A
	Temperature rise test per clause 17 after normal operation	See appended table 19.1	N/A
	After the tests the specimens not show:		N/A
	- wear impairing their further use;		N/A
	- discrepancy between the position of the actuating member (if indicated) and that of the moving contacts		N/A
	- deterioration of enclosures, insulating lining or barriers;		N/A
	- seepage of sealing compound		N/A
	- loosening of electrical or mechanical connections;		N/A
	- displacement of moving contacts of switches pattern number 2, 3, 03 or 6/2		N/A

IEC 60669-2-1			
Clause	Requirement + Test	Result - Remark	Verdict
	No sustained arcing in slowly operation (sub-clause 14.3)		N/A
	RCS equipped with an incorporated hand-operated device acting directly on the switching circuit:		N/A
	- 10 % of operations indicated in table 17 made by hand or in an equivalent manner		N/A
	- no sustained arcing in slowly operation (sub-clause 14.3 for a.c. only)		N/A
	- control circuit supplied as specified in clause 18 for the remaining 90 % of the operations		N/A
	During normal operation test: failures allowed within 1 %; no more than three consecutive failures allowed		N/A
	Electronics TDS withstand without excessive wear or other harmful effect, the mechanical, electrical and thermal stresses occurring in normal use		N/A
	- model/type reference		—
	- pattern number		—
	- nominal cross-sectional area per clause 18 (mm ²)		—
	- test voltage (Vn) (V)		—
	- test voltage applied to control circuit (rated control voltage) (V)		—
	- test current (In) (cos φ 0,6) (A)		—
	- adjustable TDS: adjusted delay time (s)		—
	- adjusted switching time interval between off and on (s)		—
	- number of operations indicated in table 17 (maximum test duration for adjustable and non-adjustable TDS: 1000 h)	40000 / 20000 / 10000 / 5000	—
	TDS equipped with an incorporated hand-operated device acting directly on the switching circuit:		N/A
	- 10 % of operations indicated in table 17 made by hand or in an equivalent manner		N/A
	- no sustained arcing in slowly operation (sub-clause 14.3 for a.c. only)		N/A
	During normal operation test: failures allowed within 1 %; no more than three consecutive failures allowed		N/A
	- samples number		—
	Reduced electric strength per clause 16	See appended table 19.1	N/A
	Temperature rise test per clause 17 after normal	See appended table 19.1	N/A

IEC 60669-2-1			
Clause	Requirement + Test	Result - Remark	Verdict
	operation		
	After the tests the specimens not show:		N/A
	- wear impairing their further use;		N/A
	- discrepancy between the position of the actuating member (if indicated) and that of the moving contacts		N/A
	- deterioration of enclosures, insulating lining or barriers;		N/A
	- seepage of sealing compound		N/A
	- loosening of electrical or mechanical connections;		N/A
	- displacement of moving contacts of switches pattern number 2, 3, 03 or 6/2		N/A
	No sustained arcing in slowly operation (sub-clause 14.3)		N/A
19.101	Contact mechanisms intended for incandescent lamp circuits with or without step down converters and dimmers for step-down converter; number of operations 40.000:		N/A
	Rate of operation (operation per minute)		—
	Rated current (A) / Rated load (W or VA)		—
	Rated voltage (V)		—
	During the test: specimens function correctly		N/A
	No sustained arcing in slowly operation (sub-clause 14.3)		N/A
	Contact mechanism intended for motor speed control circuits; number of operations 40000:		N/A
	Making: test current: $6 I_n$ (A); test voltage: V_n (V); $\cos\phi 0.65 \pm 0.05$		N/A
	Breaking: test current I_n (A); test voltage V_n (V); $\cos\phi 0.65 \pm 0.05$		N/A
	During the test: specimens function correctly		N/A
19.102	Contact mechanisms incorporated in electronic switches, intended for externally ballasted lamps (e.g. fluorescent lamps, CFL, LED) are checked by the test circuit indicated in Figure 103 Load A.		N/A
	- rate of operation (operation per minute)	30 (up to and including 10 A) / 15 (10 A to 16 A)	—
	- test voltage (V_n); test current (I_n) ($\cos \phi 0,9$); number of operations with load A	- V; - A; 10000 (up to and including 10 A) / 5000 (10 A to 16 A)	—
	Rated voltage (V)		—
	During the test: copper wire F not melt, specimens function correctly, no sustained arcing or welding of contacts		N/A

IEC 60669-2-1			
Clause	Requirement + Test	Result - Remark	Verdict
19.103	Semiconductor switching devices and/or electronic regulating units incorporated in electronic switches:		P
	Rated current (A) / Rated load (W or VA)	300 W for incandescent lamp	—
	Rated voltage (V)	100-240 V	—
	Test voltage: 1.1 Vn (V)	264 V	—
	Switch state changed 10 times by means of the sensing surface or unit, or/and		N/A
	Setting value altered 10 times from min to max and back to min by means of the sensing surface or unit		P
	Additional test, where appropriate:		N/A
	Switch state changed 10 times by means of an electronic extension unit, and/or		N/A
	Setting value altered 10 times from min to max and back to min by means of an electronic extension unit		N/A
	During the test: specimens operate correctly		P
19.104	Mechanical control units incorporate in electronic switches:		P
	Type of mechanical control unit	push button / potentiometer / other requiring manual operation	—
	Rated current (A) / Rated load (W or VA)	1) At 100-200 V rating voltage; 5-150 W for incandescent lamp ; 5-150 VA for fluorescent Lamp; electronic step-down converter for extra low-voltage incandescent lamps (for example, halogen); Iron core transformer for extra low-voltage incandescent lamps (for example, halogen); 5-37 VA for self-ballasted fluorescent compact lamp (CFL) or self-ballast LED lamp; 2) At 200-240 V rating voltage; 5-300 W for incandescent lamp; 5-300 VA for fluorescent Lamp; electronic step-down converter for extra low-voltage incandescent lamps (for example, halogen); Iron core transformer for extra low-voltage incandescent lamps	—

IEC 60669-2-1			
Clause	Requirement + Test	Result - Remark	Verdict
		(for example, halogen); 5-75 VA for self-ballasted fluorescent compact lamp (CFL) or self-ballast LED lamp	
	Rated voltage (V)	100-240 V	—
	Test voltage: 1.1 Vn (V)	264 V	—
	Setting altered 10000 times from min to max and back to min by means of its control unit; rate of operation between 10 and 15 operations per minute	10000 cycles; 10 cycles operations per minute	—
	During the test: specimens function correctly		P
19.105	Electronic switches for which a minimum load or current is specified by the manufacturer:		P
	Test current: rated minimum current (A) / rated minimum load (W or VA)	5 W for incandescent lamp	—
	Test voltage: 0,9 Vn (V)	90 V	—
	Switch state changed 10 times over the whole range from min to max and back to min, and/or		P
	Setting value altered 10 times over the whole range from min to max and back to min		P
	Additional test, where appropriate:		N/A
	Switch state changed 10 times over the whole range from min to max and back to min by means of an electronic extension unit, and/or		N/A
	Setting value altered 10 times over the whole range from min to max and back to min by means of an electronic extension unit		N/A
	During the test: electronic switch functions correctly		P
	Reduced electric strength per clause 16	See appended table 19	P
	Temperature rise test after normal operation per clause 17:		P
	- electronic switch state not change		P
	- fuses and other protective devices not operate		P
	- permissible temperature rises determined in table 102, column concerning clause 17, not exceeded	See appended table 19	P
	After the test, electronic switch is in operating condition		P
	Sealing compounds, if any, have not flowed		N/A
	Evaluation of compliance after the normal operation: after the tests the specimens shall not show:		P
	- wear impairing their further use;		P
	- discrepancy between the position of the actuating member (if indicated) and that of the moving contacts;		P

IEC 60669-2-1			
Clause	Requirement + Test	Result - Remark	Verdict
	- deterioration of enclosures, insulating lining or barriers;		P
	- loosening of electrical or mechanical connections;		P
	- seepage of sealing compound;		N/A
	- displacement of the moving contacts of electronic switches of pattern number 2		N/A
19.106	Test for electronic RCS energized by impulses (under no-load conditions):		N/A
	RCS operate as intended at a control voltage between 0,9 and 1,1 times the rated value	See appended table 19.106	N/A
	Electronic TDS operate as intended at the control voltage between 0,9 and 1,1 times the rated value		N/A
	Test (under no-load conditions):		N/A
	- rated control voltage (V)		—
	- 20 operations with a control voltage of 0,9 times the rated value (V)		—
	- 20 operations with a control voltage of 1,1 times the rated value (V)		—
	TDS operated as intended (differences in delay time permitted according to 19.102)		N/A
19.107	Electronic TDS have an adequate repetitive accuracy of delay time		N/A
	Test (under no-load conditions):		N/A
	- rated control voltage (applied ten times) (V)		—
	- adjustable TDS: delay time set 2,5 min approximately if possible, otherwise, test made with the delay time specified by the manufacturer (s)		—
	Mean value of delay times measured (s)	- s	—
	Maximum / minimum values of delay time measured (s)	- s / - s	—
	Maximum / minimum values of delay time do not deviate by more than 15 % from the mean value	- % / - %	—
19.108	Electronic TDS revert to the full delay time when the operating means is actuated during the delay time period		N/A
	Adjustable TDS: three specimens initiated at rated control voltage and after 1 min initiated again at rated control voltage:		N/A
	- rated control voltage (V)		—
	- delay time adjusted between 2 min and 3 min (s) (V)		—
	Total delay time resulting for each specimens is between 3 min and 4 min (min)		N/A

IEC 60669-2-1			
Clause	Requirement + Test	Result - Remark	Verdict

	Non-adjustable TDS: three specimens initiated at rated control voltage and after 1 min initiated again at rated control voltage:		N/A
	- rated control voltage (V)		—
	- delay time (declared by the manufacturer) (min) ..		—
	Total delay time is the delay time (declared by the manufacturer) $\pm 5\%$ plus 1 min (min)		N/A
	Non-adjustable TDS when the delay time is less than 1 min: three specimens initiated at rated control voltage and after half the delay time declared by the manufacturer initiated again at rated control voltage:		N/A
	- rated control voltage (V)		—
	- delay time (declared by the manufacturer) (min) ..		—
	Total delay time is 1,5 times the delay time (declared by the manufacturer) $\pm 5\%$ (min)		N/A
19.109	Contact mechanisms incorporated in electronic switches, intended for self-ballasted lamps (e.g. fluorescent lamps, CFL, LED) are tested as 19.102 except for the requirements related to the power supply which are given for information only.		N/A
	Compliance is checked by connecting the load B as given in figure 103 via the electronic switch under test to a power supply.		—
	The values for the maximum peak value and the maximum I^2t of the inrush current are given in table 108).....		—
	- rate of operation (operation per minute)	30 (up to and including 250 W) / 15 (higher than 250 W)	—
	During the test: copper wire F not melt, specimens function correctly, no sustained arcing or welding of contacts		N/A

20	MECHANICAL STRENGTH		P
	Switches, boxes and screwed glands have adequate mechanical strength		P
20.1	For all types of switches and for boxes: impact test (9 blows)	See appended table 20.1	P
	After the test: no damage, live parts no become accessible		P
20.2	Bases of surface-type switches first fixed to a cylinder of rigid steel sheet of radius equal to 4,5 times the distance between fixing holes (mm)		N/A
	Bases then fixed to a flat steel sheet		N/A
	Torque applied to fixing screws (Nm)	0,5 Nm / 1,2 Nm	—
	During and after the test: bases show no damage		N/A
20.3	Screwed glands of switches other than ordinary: torque test		N/A
	- diameter of cylindrical metal test rod (mm)		—

IEC 60669-2-1			
Clause	Requirement + Test	Result - Remark	Verdict
	- type of material	metal / moulded material	—
	- torque for 1 min (table 19) (Nm)		—
	After the test: no damage of glands and enclosure of the specimens		N/A
20.4	Force necessary for covers, cover-plates or actuating members to come off or not to come off (accessibility with the test finger to live parts)		N/A
20.4.1	Verification of the non-removal of covers, cover-plates or actuating member		N/A
	Force applied for 1 min in direction perpendicular to the mounting surface	40 N / 80 N	—
	Covers, cover-plates or actuating members not come off		N/A
	Test repeated on new specimens with a sheet of hard material, 1 mm ± 0,1 mm thick, fitted around the supporting frame (fig. 19)		N/A
	Covers, cover-plates or actuating members not come off		N/A
	After the test: no damage		N/A
20.4.2	Verification of the removal of covers, cover-plates or actuating members		N/A
	Force not exceeding 120 N applied 10 times in direction perpendicular to the mounting / supporting surface: covers, cover-plates or actuating members come off		N/A
	Test repeated on new specimens with a sheet of hard material, 1 mm ± 0,1 mm thick, fitted around the supporting frame (fig. 19)		N/A
	Covers, cover-plates or actuating members come off		N/A
	After the test: no damage		N/A
20.5	Force necessary for covers, cover-plates or actuating members to come off or not to come off (accessibility with the test finger to non-earthed metal parts separated from live parts by creepage distances and clearances according to table 20)		P
20.4.1	Verification of the non-removal of covers, cover-plates or actuating members		P
	Force applied for 1 min in direction perpendicular to the mounting surface	10 N / 20 N	—
	Covers or cover-plates not come off		P
	Test repeated on new specimens with a sheet of hard material, 1 mm ± 0,1 mm thick, fitted around the supporting frame (fig. 19)		P
	Covers, cover-plates or actuating members not come off		P
	After the test: no damage		P
20.4.2	Verification of the removal of covers, cover-plates or actuating members		P

IEC 60669-2-1			
Clause	Requirement + Test	Result - Remark	Verdict
	Force not exceeding 120 N applied 10 times in direction perpendicular to the mounting / supporting surface: covers, cover-plates or actuating members come off		P
	Test repeated on new specimens with a sheet of hard material, 1 mm ± 0,1 mm thick, fitted around the supporting frame (fig. 19)		P
	Covers, cover-plates or actuating members come off		P
	After the test: no damage		P
20.6	Force necessary for covers, cover-plates or actuating members to come off or not to come off (accessibility to insulating parts, earthed metal parts, live parts of SELV ≤ 25 V a.c. or metal parts separated from live parts by creepage distances twice those according to table 20)		P
20.4.1	Verification of the non-removal of covers, cover-plates or actuating members		P
	Force 10 N applied for 1 min in direction perpendicular to the mounting surface: covers, cover-plates or actuating members not come off		P
	Test repeated on new specimens with a sheet of hard material, 1 mm ± 0,1 mm thick, fitted around the supporting frame (fig. 19)		P
	Covers, cover-plates or actuating members not come off		P
	After the test: no damage		P
20.4.2	Verification of the removal of covers, cover-plates or actuating members		P
	Force not exceeding 120 N applied 10 times in direction perpendicular to the mounting / supporting surface: covers, cover-plates or actuating members come off		P
	Test repeated on new specimens with a sheet of hard material, 1 mm ± 0,1 mm thick, fitted around the supporting frame (fig. 19)		P
	Covers, cover-plates or actuating members come off		P
	After the test: no damage		P
20.7	Test with gauge of figure 20 applied according to figure 21 for verification of the outline of covers, cover-plates or actuating members: distances between face C of gauge and outline of side under test, not decrease	complying / not complying	—
20.8	Test with gauge according to figure 23 applied as shown in figure 24 (1 N): gauge not enter more than 1mm	complying / not complying	—
20.9	Operating members of cord-operated switch have adequate strength		N/A

IEC 60669-2-1			
Clause	Requirement + Test	Result - Remark	Verdict
	Pull test: pull 100 N for 1 min (normal use); pull of 50 N for 1 min (unfavourable direction). After the test:		N/A
	- switch show no damage		N/A
	- operating member not broken and cord-operated switch still operate		N/A

21	RESISTANCE TO HEAT		P
21.1	Switches kept for 1 h in a heating cabinet at a temperature of 100 °C ± 2 °C		P
	During the test: no change impairing their further use and sealing compound, if any, not flow		P
	After the test: no access to live parts, markings still legible		P
21.2	Parts of insulating material necessary to retain current-carrying parts and parts of the earthing circuit in position: ball-pressure test (1 h, 125 °C)	See appended table 21.2	P
21.3	Parts of insulating material not necessary to retain current-carrying parts and parts of the earthing circuit in position, even though in contact with them: ball-pressure test (1 h)	See appended table 21.3	P

22	SCREWS, CURRENT-CARRYING PARTS AND CONNECTIONS		P
22.1	Connections withstand mechanical stresses		P
	Thread-forming or thread-cutting screws used only if supplied together with the piece in which they are intended to be inserted		N/A
	Screws and nuts which transmit contact pressure: in engagement with a metal thread		P
	Threaded part torque test	See appended table 22.1	P
22.2	Screws in engagement with a thread of insulating material: correct introduction into the screw hole or nut ensured		N/A
22.3	Contact pressure: not transmitted through insulating material other than ceramic, pure mica or other material no less suitable unless there is sufficient resiliency in metallic parts		P
22.4	Screws and rivets locked against loosening or turning		N/A
22.5	Current-carrying parts of metal having mechanical strength, electrical conductivity and resistance to corrosion adequate:		P
	- copper;		P
	- alloy with at least 58 % copper for parts made from cold-rolled sheet or with at least 50 % copper for other parts;		P

IEC 60669-2-1			
Clause	Requirement + Test	Result - Remark	Verdict
	- stainless steel with at least 13 % chromium and not more than 0,12 % carbon		P
	- steel with electroplated coating of zinc (ISO 2081): service condition ISO no. (1/2/3); IP (X0/X4/X5); thickness (µm)		N/A
	- steel with electroplated coating of nickel and chromium (ISO 1456): service condition ISO no. (2/3/4); IP (X0/X4/X5); thickness (µm)		N/A
	- steel with electroplated coating of tin (ISO 2093): service condition ISO no. (2/3/4); IP (X0/X4/X5); thickness (µm)		N/A
	Current-carrying parts subjected to mechanical wear: not of steel with electroplated coating		N/A
	Metals having a great difference of electrochemical potential: not used in contact with each other		N/A
22.6	Contacts subjected to sliding action: of metal resistant to corrosion		P
22.7	Thread-forming screws and thread-cutting screws not used for the connection of current-carrying parts		N/A
	Thread-forming screws and thread-cutting screws used to provide earthing continuity: not necessary to disturb the connection and at least two screws are used for each connection		N/A

23	CREEPAGE DISTANCES, CLEARANCES AND DISTANCES THROUGH SEALING COMPOUND		P
	Values of items 1, 2, 6 and 7 of table 20 applied to terminals for external wiring and not applied to other live parts which are protected by a directly associated fuse with adequate breaking capacity or other current-limiting means, under the provision that the requirements of 101 are fulfilled		P
	Electronic switches without directly associated fuse or other current-limiting means: comply with table 20		P
23.1	Creepage distances, clearances and distances through sealing compound no less than the values shown in table 20	See appended table 23.1	P
23.2	Insulating compound: not protrude above the edge of the cavity in which it is contained		N/A
23.101	Electronic switches having control circuit suitable for connection to a SELV supply, the switching circuit being supplied with a voltage greater than the SELV: creepage distances and clearances between the control and switching circuits are not less than 5,5 mm (mm)		N/A

IEC 60669-2-1			
Clause	Requirement + Test	Result - Remark	Verdict

	In case of electronic RCS and electronic TDS classified according to 7.103, see the relevant requirements in IEC 60669-2-2 and IEC 60669-2-3 for clearance and creepage between SELV and mains. (mm)		N/A
23.102	Wire enamel at least grade 1 according to IEC 60317: clearances between the wire of the control coil, live parts of different polarity and exposed conductive parts may be reduced to a value equal to two-thirds the clearances required in absence of enamel		N/A

24	RESISTANCE OF INSULATING MATERIAL TO ABNORMAL HEAT, TO FIRE AND TO TRACKING		P
24.1	Parts of insulating material which might be exposed to thermal stresses due to electric effects and the deterioration of which might impair the safety are not unduly affected by abnormal heat and fire		P
24.1.1	Glow-wire test according to IEC 60695-2-1	See appended table 24.1.1	P
24.2	Parts of insulating material retaining live parts in position of switches with IP>X0: of material resistant to tracking		N/A
	Tracking test with solution A of IEC 60112	See appended table 24.2	N/A

25	RESISTANCE TO RUSTING		P
	Ferrous parts protected against rusting		P
	Test: 10 min in carbontetrachloride, trichloroethane or equivalent degreasing agent, 10 min 10 % solution of ammonium chloride, 10 min in a box with air saturated with moisture and 10 min at 100 °C ± 5 °C:		P
	No signs of rust		P

26	EMC REQUIREMENTS		P
	Electronic switches designed to operate correctly under the conditions of electromagnetic environment in which they are intended to be used		P
26.1	Immunity		P
	Electronic switches designed so that the switch state (ON or OFF) and/or the setting value are protected against interference		P
	Type of load	1) At 100-200 V rating voltage; 5-150 W for incandescent lamp ; 5-150 VA for fluorescent Lamp; electronic step-down	—

IEC 60669-2-1			
Clause	Requirement + Test	Result - Remark	Verdict
		converter for extra low-voltage incandescent lamps (for example, halogen); Iron core transformer for extra low-voltage incandescent lamps (for example, halogen); 5-37 VA for self-ballasted fluorescent compact lamp (CFL) or self-ballast LED lamp; 2) At 200-240 V rating voltage; 5-300 W for incandescent lamp; 5-300 VA for fluorescent Lamp; electronic step-down converter for extra low-voltage incandescent lamps (for example, halogen); Iron core transformer for extra low-voltage incandescent lamps (for example, halogen); 5-75 VA for self-ballasted fluorescent compact lamp (CFL) or self-ballast LED lamp	
	Test current: In (A) / Rated load (W or VA)	At 100-200 V rating voltage; 5-150 W for incandescent lamp ; 5-150 VA for fluorescent Lamp; electronic step-down converter for extra low-voltage incandescent lamps (for example, halogen); Iron core transformer for extra low-voltage incandescent lamps (for example, halogen); 5-37 VA for self-ballasted fluorescent compact lamp (CFL) or self-ballast LED lamp; At 200-240 V rating voltage; 5-300 W for incandescent lamp; 5-300 VA for fluorescent Lamp; electronic step-down converter for extra low-voltage incandescent lamps (for example, halogen); Iron core transformer for extra low-voltage incandescent lamps (for example, halogen);	—

IEC 60669-2-1			
Clause	Requirement + Test	Result - Remark	Verdict
		5-75 VA for self-ballasted fluorescent compact lamp (CFL) or self-ballast LED lamp	
	Test voltage: Vn (V)	100-240 V	—
	Variation of less than $\pm 10\%$ of the value of the output power (rms) is not considered to be a change of setting		P
	Electronic switches shall be tested according to Table 104 with or without operation as specified in the relevant paragraph.		P
	If the load connected to the electronic switch is controlled by mechanical switching devices and no semiconductor devices are present in the load circuit, test is conducted with resistive load only		—
	For test without operation the electronic switch is tested in the following states:		P
	a) in the ON state		P
	b) in the ON state		N/A
	For electronic switches whose cycle of operation is limited by their application, the rate of operation during the test shall be specified by the manufacturer.		—
26.1.1	Voltage dips and short interruptions		P
	Electronic switch tested using the equipment specified in IEC 61000-4-11 in accordance with table 105: sequence: 3 dips/interruptions (duration: 10 cycles at rated frequency) with interval of 10 s minimum between each test event:		P
	The test shall be done on the power supply lines of the electronic switch.		P
	During the test, the electronic switch is not operated		P
	During the test, the state and setting of electronic switch may alter, flickering is neglected.		P
	Test level: 0 % U_T		P
	Test level: 40 % U_T		P
	Test level: 70 % U_T		P
	After the test: electronic switch is in the original state and the setting is unchanged		P
	After the test, the electronic switch shall be in the original state and setting and shall operate as intended.		P
26.1.2	Surge immunity test for 1,2/50 μ s wave impulses		P
	Test carried out according to IEC 61000-4-5 applying two positive discharges and two negative discharges at each of the following angles 0°, 90°, 270°, at a repetition rate of (60 ± 5) s, with an open-circuit test voltage of Table110		P
	A test with lower voltages is not required		P

IEC 60669-2-1			
Clause	Requirement + Test	Result - Remark	Verdict
	During the test , the electronic switch is not operated		P
	During the test , the state and setting of electronic switch may alter, flickering is neglected.		P
	After the test, the electronic switch shall be in the original state and setting and shall operate as intended.		P
26.1.3	Electrical fast transient/burst test		P
	Test carried out according to IEC 61000-4-4 in accordance with table 106, duration of the test 1 min +5/0 s for each positive and negative polarities: open-circuit output test voltage ($\pm 10\%$):		P
	During the test , the electronic switch is not operated		P
	Supply terminals/terminations: 1 kV		P
	Control terminals/terminations: 0,5 kV		P
	During the test, the state and setting of the electronic switch may alter, flickering caused by the electronic switch is allowed.		P
	After the test: the electronic switch shall be in the original state and setting and shall operate as intended.		P
26.1.4	Electrostatic discharge test		P
	Electronic switch not intended to operate resistive load: test carried out with only one load of the loads specified within the manufacturer's instructions		P
	Test carried out according to EN 61000-4-2 applying 10 positive and 10 negative discharge:		P
	A test with lower voltages is not required		P
	During the test , the electronic switch is not operated		P
	During the test , the state and setting of electronic switch may alter, flickering is neglected.		P
	- contact discharge to the conductive surface and to coupling planes (test voltage: 4 kV)		P
	- air discharge at insulating surfaces (test voltage: 8 kV)		P
	After the test: the electronic switch shall be in the original state and setting and shall operate as intended.		P
	Electronic switches with an adjustable time delay devices shall be adjusted in such way that the time delay is higher than the testing time		P
26.1.5	Radiated electromagnetic field test		P

IEC 60669-2-1			
Clause	Requirement + Test	Result - Remark	Verdict
	Test applicable only to electronic switches containing infra-red (IR) receivers, radio frequency receivers, passive infra-red (PIR) devices, devices containing microprocessors or similar		P
	Test carried out according to IEC 61000-4-3 applying a field strength of 3 V/m in the frequency range 80 MHz to 1000 MHz and 1400 MHz to 2000 MHz:		P
	Electronic switch shall be loaded with resistive load only.		P
	During the test, the electronic switch is operated, if it contains automatics functions or can be remotely controlled		P
	During the test , the electronic switch shall operate as intended, flickering is not allowed.		P
	Flickering of lamps or irregular running of motors due to the switching transient caused by frequency changes of the test equipment during the test procedure is neglected.		P
26.1.6	Radio-frequency voltage test		P
	Test applicable only to electronic switches containing infra-red (IR) receivers, radio frequency receivers, passive infra-red (PIR) devices, devices containing microprocessors or similar		P
	Electronic switch shall be loaded with resistive load only.		P
	Test carried out according to IEC 61000-4-6 applying a conducted radio-frequency voltage of 3 V r.m.s. on supply lines and control lines:		P
	During the test, the electronic is operated, if it contains automatics functions or can be remotely controlled		P
	During and after the test , the electronic switch shall operate as intended, flickering is not allowed.		P
	Flickering of lamps or irregular running of motors due to the switching transient caused by frequency changes of the test equipment during the test procedure is neglected.		P
26.1.7	Power-frequency magnetic field test		N/A
	Test applicable only to electronic switches containing devices susceptible to magnetic fields, for example, Hall elements, electrodynamic microphones, etc.		N/A
	Test carried out according to IEC 61000-4-8 applying a magnetic field of 3 A/m, 50 Hz:		N/A
	Electronic switch shall be loaded with resistive load only.		N/A
	During the test, the electronic is operated, if it contains automatics functions or can be remotely controlled		N/A

IEC 60669-2-1			
Clause	Requirement + Test	Result - Remark	Verdict

	During and after the test , the electronic switch shall operate as intended, flickering is not allowed.		N/A
	Flickering of lamps or irregular running of motors due to the switching transient caused by frequency changes of the test equipment during the test procedure is neglected.		N/A
26.2	Emission		P
26.2.1	Low-frequency emission		P
	Electronic switches designed that they do not cause excessive disturbances in the network		N/A
	Electronic switch complies with IEC 61000-3-2 and IEC 61000-3-3		P
	This requirements applies to each channel of a multichannel dimmer provided that the channel are independent from each other		N/A
	Load terminals/terminations of electronic switches with electromechanically operated contact mechanism (for example, a relay), do not cause harmonic current emissions and are deemed to meet the requirements of IEC 61000-3-2 without need for testing. Therefore only the mains supply terminal/terminations of those products shall be tested.		P
26.2.2	Radio-frequency emission		P
	Electronic switches designed that they do not cause excessive radio interference		P
	Electronic switch complies with the requirements of CISPR 14 or CISPR 15.		N/A
	Electronic switch complies with the requirements of CISPR 15 (modified on sub-clauses 8.1.4.2 and 8.1.4.3)		P

101	ABNORMAL CONDITIONS		P
	Electronic switches do not create hazard under abnormal conditions		P
	If in case of failure the maximum power taken by the electronic switches is less than 0,5 W, the requirements of the abnormal condition are deemed to be met		P
101.1.1.1	Fault conditions test: temperature rises not exceed the values given in table 102, column concerning clause 101	See appended table 101.1.1.1	P
	Temperature limited by a fuse: additional test carried out in case of doubt	See appended table 101.1.1.1	P
101.1.1.2	Electronic switches without incorporated temperature-limiting devices and without incorporated fuses:		N/A

IEC 60669-2-1			
Clause	Requirement + Test	Result - Remark	Verdict
	Test current: conventional tripping current I_f (A) for 1h of the fuse which, in the installation, will protect the electronic switch		—
	Temperature rise measured after steady state or after 4 h	See appended table 101.1.1.2	N/A
	Electronic switches protected by automatic protective devices (including fuses):		P
	Current with which the protecting device releases after 1 h (A)	1,95 A (Circuit protection operated before thermal link operated for the product covered by test report)	—
	Test current: 0.95 times the current with which the protecting device releases after 1 h (A)	1,85 A	—
	Temperature rise measured after steady state or after 4 h	See appended table 101.1.1.2	P
	Electronic switches protected by incorporated fuses complying with IEC 60127:		N/A
	Rated current of incorporated fuse (A)		—
	Test current: $2.1 I_n$ (A)		—
	Temperature rise measured after 30 min	See appended table 101.1.1.2	N/A
	Additional test on new specimen shall be carried out, if in any of the previous test the electronic switch turn off before the temperature has been steady state:		N/A
	Test current: $1.1 I_n$ (A)		—
	Test current then increased by 10% until temperature stabilize		—
	The above test is repeated by 10 % until the conventional tripping current of the protective device is reached or the electronic switch is destroyed		—
101.2	Protection against electric shock even during fault conditions		P
	Electronic switches tested according to clause 10 immediately following the test of 101.1		P
101.3*	Short circuit test: prospective short circuit of the supply: 1500 A; I^2t : 15000 A ² s:		P
	Test voltage V_n (V)	100 V - 240 V	—
	Type of fuse recommended by the manufacturer ..	Thermal link	—
	N° of short circuits; N° of specimens used	6 pcs	—
	During the test, emission of flames or burning particles, if any, shall not be dangerous to the environment.		P
	The above requirement is fulfilled if during the test there are no emission of flame or burning particles visible without magnification.		P
	If there is a visible emission, the test shall repeated		P

IEC 60669-2-1			
Clause	Requirement + Test	Result - Remark	Verdict
	using a polyethylene film.		
	After the test:		P
	- accessible metal parts not live		P
	- emissions of flame or burning particles have not visibly perforated the film when examined without magnification		P
	- the conductors, the flush mounting box and mounting surface shall not show traces of burns. Traces which can be cleaned are ignored		P
	- the specimen is re-energized in its normal operating position, and its behaviour is monitored for 4 h. The specimen shall show no dangerous behaviour, maximum temperature of Table 102 shall not be exceeded.		P
	- the electronic switches shall withstand the dielectric strength test of Clause 16. Overcurrent protective devices which can be manually reset shall be switched on before the test.	See appended table 101.3	P
101.4	Abnormal operation of the control circuit (only for electronic RCS energized by impulses)		N/A
	Behaviour of electronic RCS during abnormal operation of the control circuit is not dangerous		N/A
	Test made on three additional specimens of electronic RCS meeting with requirements of clauses 15 and 16:		N/A
	Control circuit continuously energized at its rated voltage (V)		—
	Switching circuit loaded for 1 h with rated current (A) at rated voltage (V)	- A; - V	—
	After this test:		N/A
	- RCS still operate		N/A
	- temperature rise of any part of the electronic RCS enclosure and plywood support, which may be touched by the standard test finger, test probe B of IEC 61032, ≤ 75 K (K)		N/A
	- temperature rise of the plywood support which cannot be touched by the standard test finger, test probe B of IEC 61032, ≤ 100 K (K)		N/A
	- electronic RCS did not emit flames, melted material, glowing particles or burning drops of insulating material		N/A
	After cooling down to ambient temperature:		N/A
	Electronic RCS withstand a dielectric test (sub-clause 16.2), test voltage (a.c., for 1 min), between switching and control circuits:		N/A
	- test voltage (V)		—

IEC 60669-2-1			
Clause	Requirement + Test	Result - Remark	Verdict
	During the test: no flashover or breakdown		N/A
	Electronic RCS still meet the requirements of 10.1		N/A
	Electronic RCS coil is then intermittently energized for 1 h using a voltage equal to its rated control voltage, the switching circuit being supplied with rated current at rated voltage:		N/A
	class of insulating material		—
	temperature-rise limit (IEC 60085) (K)		—
	temperature-rise measured (K)		N/A
	Behaviour of electronic TDS during abnormal operation of the control circuit is not dangerous		N/A
	Test made on three additional specimens of electronic TDS meeting with requirements of clauses 15 and 16:		N/A
	Control circuit continuously energized at its rated voltage (V)		—
	Switching circuit loaded for 6 h with rated current (A) at rated voltage (V)	- A; - V	—
	Adjustable electronic TDS: adjusted to the shortest delay time (s).....		—
	After this test:		N/A
	- electronic TDS still operate		N/A
	- temperature rise of any part of the electronic TDS enclosure and plywood support, which may be touched by the standard test finger, test probe B of IEC 61032, ≤ 75 K (K)		N/A
	- temperature rise of the plywood support which cannot be touched by the standard test finger, test probe B of IEC 61032, ≤ 100 K (K)		N/A
	- electronic TDS did not emit flames, melted material, glowing particles or burning drops of insulating material		N/A
	After cooling down to ambient temperature:		N/A
	Electronic TDS withstand a dielectric test (sub-clause 16.2), test voltage (a.c., for 1 min), between switching and control circuits:		N/A
	- test voltage (V)		—
	During the test: no flashover or breakdown		N/A
	Electronic TDS still meet the requirements of 10.1		N/A
101.5	Dimmers for incandescent and/or self-ballasted lamps shall so designed that no part shall reach such a temperature that there is danger of fire to the surrounding of the dimmer when non-dimmable self-ballasted lamps are installed in the load circuit.		N/A
	Tests made on dimmers mounted and connected as specified in clause 17.		N/A

IEC 60669-2-1			
Clause	Requirement + Test	Result - Remark	Verdict
	The dimmer is loaded with a number of lamp simulation circuit as Figure 103 Load B (25 W non dimmable self-ballasted lamp)		—
	Dimmer not for self-ballasted lamps the dimmer is loaded with a number of lamp simulation circuit as Figure 103 Load B having a total power equivalent to 1/5 th of the declared incandescent lamp load (W)		—
	- test voltage (V)		—
	- permissible temperature rises determined in table 102, column concerning clause 101, not exceeded	See appended table 101.1.1.2	N/A
	After this test:		N/A
	- accessible metal parts shall not be live		N/A
	- contacts of any incorporated automatic protective device not welded, unless the electronic switch is obviously useless		N/A

102	COMPONENTS		P
	Components which, if they fail, may impair the safety of the electronic switch comply with the relevant IEC standards, as far as applicable		P
	Components marked with their operating characteristics used in accordance with these markings		P
102.1	Fuses comply with:		N/A
	- IEC 60127		N/A
	- other relevant IEC publications		N/A
	Rated breaking capacity (A): 1500 A or 35 A		N/A
102.2	Capacitors: the short-circuiting or disconnection of which cause an infringement of the requirements under fault conditions with regard to shock or fire hazard:		N/A
	Trade mark; article of capacitor		—
	Capacitor complies with IEC 60384-14		N/A
	Capacitor passing the damp heat steady-state test specified in 4.12 of IEC 60384-14 with a duration of not less than 21 days are considered acceptable		N/A
	Capacitor in accordance with table 107: approved type of capacitor required by table 107 according to the application in the electronic switch; observed		N/A
	Capacitor marked with:		N/A
	- rated voltage (V)		N/A
	- rated capacitance (µF)		N/A
	- reference temperature (°C)		N/A

IEC 60669-2-1			
Clause	Requirement + Test	Result - Remark	Verdict
	Capacitors: the short-circuiting of which cause a current = 0,5 A through the terminals of the capacitor:		N/A
	Trade mark; article of capacitor		—
	Capacitor complies with IEC 60384-14		N/A
	Capacitor passing the damp heat steady-state test specified in 4.12 of IEC 60384-14 with a duration of not less than 21 days are considered acceptable		N/A
	Capacitor in accordance with table 107: approved type of capacitor required by table 107 according to the application in the electronic switch; observed		N/A
	Capacitor marked with:		N/A
	- rated voltage (V)		N/A
	- rated capacitance (µF)		N/A
	- reference temperature (°C)		N/A
	Capacitors: for suppression of electromagnetic interference:		N/A
	Trade mark; article of capacitor		—
	Capacitor complies with IEC 60384-14		N/A
	Capacitor passing the damp heat steady-state test specified in 4.12 of IEC 60384-14 with a duration of not less than 21 days are considered acceptable		N/A
	Capacitor in accordance with table 107: approved type of capacitor required by table 107 according to the application in the electronic switch; observed		N/A
	Capacitor marked with:		N/A
	- rated voltage (V)		N/A
	- rated capacitance (µF)		N/A
	- reference temperature (°C)		N/A
102.3	Resistors: the short-circuiting or interruption of which cause an infringement of the requirements with regard to the protection against fire and electric shock in case of a defect:		N/A
	Manufacturer / characteristics of resistor	/ Ω	—
	- constant value under overload conditions		N/A
	reference temperature of the resistor according to clause 17 (°C)		—
	- comply with sub-clause 14.1 of IEC 60065		N/A
102.4	Automatic protective devices (other than fuses)		P
	Automatic protective devices comply with IEC 60730 as far as applicable	Thermal link certified by IEC/EN 60691	P
102.4.1	Automatic protective devices which switch off the current (cut-outs):		N/A
	Adequate making and breaking capacity		N/A

IEC 60669-2-1			
Clause	Requirement + Test	Result - Remark	Verdict
	Reference temperature above 55 °C: specimens tested at reference temperature according to clause 17 (°C)		N/A
102.4.1.1	Non-self-resetting cut-outs in the load circuit of the electronic switch:		N/A
	Test voltage: 1.1 V _n (V)		—
	Cut-outs in electronic switches for incandescent or fluorescent lamps:		N/A
	10 cycles; test current: 2.1 I _n (A) of the protecting fuse (IEC 60127) or the conventional fusing current (other fuses)		—
	During the test: no sustained arcing		N/A
	After the test: specimens show no damage		N/A
	Electric strength between open contacts: test voltage 500 V a.c. for 1 min		N/A
	Cut-outs in electronic switches for speed control circuits:		N/A
	I _n (A) of electronic switch (cosφ 0.6)		—
	Making: 10 operations with: test current: 9 I _n (A); cosφ 0.8 ± 0.05		—
	Breaking: 10 operations with: test current: 6 I _n (A); cosφ 0.6 ± 0.05		—
	During the test: no sustained arcing		N/A
	After the test: specimens show no damage		N/A
	Electric strength between open contacts: test voltage (V): 1200 V a.c. (V _n ≤ 130 V) or 2000 V (V _n > 130 V) for 1 min:		N/A
102.4.1.2	Self-resetting cut-outs in the load circuit of the electronic switch:		N/A
	Test voltage: 1.1 V _n (V)		—
	Cut-outs in electronic switches for incandescent lamps:		N/A
	200 cycles; test current: 2.1 I _n (A) of the protecting fuse (IEC 60127) or conventional fusing current (other fuses)		—
	During the test: no sustained arcing		N/A
	After the test: specimens show no damage		N/A
	Test voltage (V) for cuts-out in electronic switches for speed control circuit: 1200 V a.c. (V _n ≤ 130 V) or 2000 V (V _n > 130 V) for 1 min:		N/A
	Test voltage (V) for cuts-out in electronic switches for lighting circuit: 500 V a.c. for 1 min:		N/A
102.4.2	Automatic protective devices which only decrease current to the electronic switch (10 cycles):		N/A
	Test current per clause 17 for 4 h (A)		—
	Test current increased to 2.1 I _n (A) of the protecting fuse (IEC 60127) or the conventional		—

IEC 60669-2-1			
Clause	Requirement + Test	Result - Remark	Verdict
	fusing current (other fuses) for 30 min		
	After the test: specimens function correctly		N/A
	Temperature rise test per clause 17:		N/A
	- electronic switch state not change		N/A
	- fuses and other protective devices not operate		N/A
	- permissible temperature rises determined in table 102, column concerning clause 17, not exceeded	See appended table 102.4.2	N/A
	After the test, electronic switch is in operating condition		N/A
	Sealing compounds, if any, have not flowed		N/A
102.5	Transformer		N/A
	Transformers intended for SELV circuits shall be of the safety isolating type and shall comply with the relevant requirements of IEC 61558-2-6.		N/A

ANNEC CC	ADDITION REQUIREMENTS FOR ELECTRONIC SWITCHES USING DLT_TECNOLOGY ACCORDING TO IEC 62756-1		N/A
CC.8	MARKING		N/A
CC.8.1	Switches marked with:		N/A
	- the symbol for DLT control device (DLT):		N/A
CC.8.2	Symbols used:		N/A
	DLT control device.....(DLT):		N/A
	Supported telegram types for DLT control devices (TPX).....:		N/A
	DLT controlled load.....:		N/A
	The maximum cable length between DLT control device and DLT load shall also be given in the instruction sheet.		N/A
CC.17	TEMPERATURE RISE		N/A
	In lamp dimmer, DLT control devices and speed controllers, the setting is adjusted such that the highest temperature will occur.		N/A
CC.19	NORMAL OPERATION		N/A
CC.19.103	Semiconductor switching devices and/or electronic regulating devices including DLT control devices incorporated in electronic switches are subjected to the following test.		N/A
	For DLT control devices, a cable , having the maximum cable length, as declared in 8.3, is installed between the control device and the loads.		N/A
CC.26	EMC REQUIREMENTS		N/A
CC.26.2	Emission		N/A

IEC 60669-2-1			
Clause	Requirement + Test	Result - Remark	Verdict
CC.26.2.1	Low-frequency emission		N/A
	DLT control devices shall be tested with maximum resistive load		N/A

IEC 60669-2-1			
Clause	Requirement + Test	Result - Remark	Verdict

12.2.5	TABLE: test with apparatus shown in figure 10 (screw terminals)			P
	rated current (A)	1,5 A		—
	type of conductors	rigid solid / rigid stranded		—
	smallest/largest cross-sectional area per table 2 (mm ²)	1,0 mm ²		—
	number of conductors.....	1		—
	nominal diameter of thread (mm); torque per table 3 (Nm)	3,0 mm; 0,5 Nm		—
Cross-sectional area (mm ²)	Diameter of bushing hole per table 4 (mm)	Height H per table 4 (mm)	Mass (kg)	Remarks
1,0-2,5 mm ²	6,5-9,5 mm	260-280 mm	0,4-0,7 kg	Pass
supplementary information: —				

12.2.6	TABLE: pull test (screw terminals)			P
	rated current (A)	1,5 A		—
	smallest/largest cross-sectional area per table 2 (mm ²)	1,0-2,5 mm ²		—
	nominal diameter of thread (mm); torque 2/3 per table 3 (Nm)	3 mm; 0,34 Nm		—
Cross-sectional area (mm ²)	Number of conductors	Type of conductors (rigid solid / rigid stranded)	Pull per table 5 applied for 1 min (N)	Remarks
1,0-2,5 mm ²	1	rigid solid	40-50 N	Pass
supplementary information: —				

12.2.7	TABLE: tightening test (screw terminals)			P
	rated current (A)	1,5 A		—
	nominal diameter of thread (mm); torque 2/3 per table 3 (Nm)	3 mm; 0,34 Nm		—
Largest cross-sectional area per table 2 (mm ²)	Permissible number of conductors	Type of conductors (rigid solid / rigid stranded)	Number of wires and nominal diameter of wires per table 6	Remarks
1,0-2,5 mm ²	1	rigid solid	1	Pass
supplementary information: —				

IEC 60669-2-1			
Clause	Requirement + Test	Result - Remark	Verdict

12.3.10	TABLE: mechanical stresses occurring in normal use			N/A	
	rated current (A)			—	
	largest/smallest cross-sectional area per table 7 (mm ²)			—	
	Number of connection (after that conductor subjected to a pull of 30 N for 1 min) / disconnection	Type of conductor (solid / rigid stranded / flexible)	Cross-sectional area (mm ²)	Remarks	
	TABLE: test with apparatus shown in figure 10			N/A	
	rated current (A)			—	
	type of conductors	rigid solid / rigid stranded		—	
	smallest/largest cross-sectional area per table 7 (mm ²)			—	
	number of conductors.....			—	
	Cross-sectional area (mm ²)	Diameter of bushing hole per table 4 (mm)	Height H per table 4 (mm)	Mass (kg)	Remarks
supplementary information:					

12.3.11	TABLE: electrical and thermal stresses occurring in normal use			N/A
Test a)	Test carried out for 1 h connecting rigid solid conductors:			N/A
	test current per table 8 (A)			—
	nominal cross-sectional area (mm ²)			—
	Screwless terminal number	Voltage drop (mV)	Required voltage drop	
	1		≤ 15 mV	
	2		≤ 15 mV	
	3		≤ 15 mV	
	4		≤ 15 mV	
	5		≤ 15 mV	
Test b)	Temperature cycles test) carried out on terminals subjected to Test a):			N/A
	test current per table 8 (A)			—
	nominal cross-sectional area (mm ²)			—

IEC 60669-2-1							
Clause	Requirement + Test				Result - Remark		Verdict
	allowed voltage drop (mV)				≤ 22,5 mV or 2 times 24 th cycle value (mV)		—
Screwless terminal number	1	2	3	4	5	Remarks	
voltage drop after 24 th cycle							
voltage drop after 48 th cycle							
voltage drop after 72 th cycle							
voltage drop after 96 th cycle							
voltage drop after 120 th cycle							
voltage drop after 144 th cycle							
voltage drop after 168 th cycle							
voltage drop after 192 th cycle							
12.3.10	TABLE: mechanical stresses occurring in normal use					N/A	
	rated current (A)						—
	largest/smallest cross-sectional area per table 7 (mm ²)						—
Number of connection (after that conductor subjected to a pull of 30 N for 1 min) / disconnection	Type of conductor (solid / rigid stranded / flexible)		Cross-sectional area (mm ²)		Remarks		
	TABLE: test with apparatus shown in figure 10					N/A	
	rated current (A)						—
	type of conductors			rigid solid / rigid stranded		—	
	smallest/largest cross-sectional area per table 7 (mm ²)						—
	number of conductors.....						—
Cross-sectional area (mm ²)	Diameter of bushing hole per table 4 (mm)		Height H per table 4 (mm)		Mass (kg)		Remarks
supplementary information:							

IEC 60669-2-1			
Clause	Requirement + Test	Result - Remark	Verdict

12.3.12	TABLE: deflection test (principle of test apparatus shown in figure 11a)						N/A
	Test carried out for 1 h connecting rigid solid conductors:						N/A
	test current (A) (equal rated current)						—
	required voltage drop (mV)	≤ 25 mV					—
Type of conductor	Smallest			Largest			Remarks
cross-sectional area per table 9 (mm ²)							
force per table 10 (N)							
screwless terminal number	1	2	3	1	2	3	
starting point (X = deflection original point)	X	X+10°	X+20°	X	X+10°	X+20°	
voltage drop 1 st deflection (mV)							
voltage drop 2 nd deflection (mV)							
voltage drop 3 rd deflection (mV)							
voltage drop 4 th deflection (mV)							
voltage drop 5 th deflection (mV)							
voltage drop 6 th deflection (mV)							
voltage drop 7 th deflection (mV)							
voltage drop 8 th deflection (mV)							
voltage drop 9 th deflection (mV)							
voltage drop 10 th deflection (mV)							
voltage drop 11 th deflection (mV)							
voltage drop 12 th deflection (mV)							
supplementary information:							

16.1	TABLE: insulation resistance			P
item per table 14	test voltage applied between:	measured (MΩ)		required (MΩ)
1	Between all poles connected together and the body, with the switch in the "on" position	>100		5
supplementary information: —				

IEC 60669-2-1			
Clause	Requirement + Test	Result - Remark	Verdict

16.2	TABLE: electric strength			P
item per table 14	test voltage applied between:	test voltage (V)	flashover / breakdown (Yes/No)	
1	Between all poles connected together and the body, with switch in "on" position	2000 V	NO	
2	Between live parts and accessible metal parts	3000 V	N/A	
3	Between live parts and metal knobs, push-buttons and the like	4000 V	N/A	
supplementary information: —				

17	TABLE: temperature rise measurements			P
	cross-sectional area of conductor not less than 1,5 mm ² (mm ²) (table 15)	2,5 mm ²	—	
	terminal screws: torque (Nm) (2/3 table 3 or appropriate figures 1, 2, 3, 4)	0,34 Nm	—	
	type of load	1) At 100-200 V rating voltage; 5-150 W for incandescent lamp; 5-150 VA for fluorescent Lamp; electronic step-down converter for extra low-voltage incandescent lamps (for example, halogen); Iron core transformer for extra low-voltage incandescent lamps (for example, halogen); 5-37 VA for self-ballasted fluorescent compact lamp (CFL) or self-ballast LED lamp; 2) At 200-240 V rating voltage; 5-300 W for incandescent lamp; 5-300 VA for fluorescent Lamp; electronic step-down converter for extra low-voltage incandescent lamps (for example, halogen); Iron core transformer for extra low-voltage incandescent lamps (for example, halogen); 5-75 VA for self-ballasted fluorescent compact lamp (CFL) or self-ballast LED lamp	—	

IEC 60669-2-1			
Clause	Requirement + Test	Result - Remark	Verdict

	rated current (A) / rated load (W or VA) :	<p>1) At 100-200 V rating voltage; 5-150 W for incandescent lamp; 5-150 VA for fluorescent Lamp; electronic step-down converter for extra low-voltage incandescent lamps (for example, halogen); Iron core transformer for extra low-voltage incandescent lamps (for example, halogen); 5-37 VA for self-ballasted fluorescent compact lamp (CFL) or self-ballast LED lamp;</p> <p>2) At 200-240 V rating voltage; 5-300 W for incandescent lamp; 5-300 VA for fluorescent Lamp; electronic step-down converter for extra low-voltage incandescent lamps (for example, halogen); Iron core transformer for extra low-voltage incandescent lamps (for example, halogen); 5-75 VA for self-ballasted fluorescent compact lamp (CFL) or self-ballast LED lamp</p>	—
--	---	--	---

	rated voltage (V)	100-240 V	—
--	-------------------------	-----------	---

	test voltage between 0,9 and 1,1 Vn (V), whichever is the more unfavourable	264 V and 220 V	—
--	---	-----------------	---

parts of the electronic switch	max. measured temperature (°C) 300 W for incandescent lamp (Test voltage = 264 V)	max. measured temperature (°C) 75 VA for self-ballasted fluorescent lamp (CFL) (Test voltage = 264 V)	permissible temperature (°C)
Supply cord (L)	59	39	80
Internal surface of enclosure near U1 and PCB side	70	44	Ref.
Terminal block near PCB	64	41	Ref.
Thermal link (F1)	88	49	Ref.
PCB under U1	89	52	T130
Adjusted component near PCB (U1)	93	49	Ref.
Q1 body	82	54	Ref.
Choke (L1)	97	51	Ref.
External surface of enclosure near U1	75	44	95
External surface of enclosure near Q1 body	65	43	95

IEC 60669-2-1			
Clause	Requirement + Test	Result - Remark	Verdict

Terminal block external surface (N)	66	41	95
Adjusted button plastic external surface	59	38	95
Mounting surface	51	37	95
External surface of mounting box (top near relay and fuse)	43	33	95
External surface of mounting box (bottom, near mounting surface)	39	32	95
supplementary information: —			

parts of the electronic switch	max. measured temperature (°C) 300 W for incandescent lamp (Test voltage = 220 V)	max. measured temperature (°C) 150 W for incandescent lamp (Test voltage = 220 V)	permissible temperature (°C)
Supply cord (L)	59	50	80
Internal surface of enclosure near U1 and PCB side	71	61	Ref.
Terminal block near PCB	71	55	Ref.
Thermal link (F1)	90	70	Ref.
PCB under U1	92	80	T130
Adjusted component near PCB (U1)	97	70	Ref.
Q1 body	84	88	Ref.
Choke (L1)	99	74	Ref.
External surface of enclosure near U1	78	59	95
External surface of enclosure near Q1 body	65	62	95
Terminal block external surface (N)	71	55	95
Adjusted button plastic external surface	59	52	95
Mounting surface	50	47	95
External surface of mounting box (top near relay and fuse)	45	38	95
External surface of mounting box (bottom, near mounting surface)	45	37	95
supplementary information: —			

IEC 60669-2-1			
Clause	Requirement + Test	Result - Remark	Verdict

19	TABLE: reduced electric strength after normal operation			P
item per table 20	test voltage applied between:	test voltage (V)	flashover / breakdown (Yes/No)	
1	Between all poles connected together and the body, with switch in "on" position	2000 V	NO	
2	Between live parts and accessible metal parts	3000 V	N/A	
3	Between live parts and metal knobs, push-buttons and the like	4000 V	N/A	

supplementary information: —

	TABLE: temperature rise measurements after normal operation		P
	cross-sectional area of conductor not less than 1,5 mm ² (mm ²) (table 15)	2,5 mm ²	—
	terminal screws: torque (Nm) (2/3 table 3 or appropriate figures 1, 2, 3, 4)	0,34 Nm	—
	type of load	1) At 100-200 V rating voltage; 5-150 W for incandescent lamp; 5-150 VA for fluorescent Lamp; electronic step-down converter for extra low-voltage incandescent lamps (for example, halogen); Iron core transformer for extra low-voltage incandescent lamps (for example, halogen); 5-37 VA for self-ballasted fluorescent compact lamp (CFL) or self-ballast LED lamp; 2) At 200-240 V rating voltage; 5-300 W for incandescent lamp; 5-300 VA for fluorescent Lamp; electronic step-down converter for extra low-voltage incandescent lamps (for example, halogen); Iron core transformer for extra low-voltage incandescent lamps (for example, halogen); 5-75 VA for self-ballasted fluorescent compact lamp (CFL) or self-ballast LED lamp	—

IEC 60669-2-1			
Clause	Requirement + Test	Result - Remark	Verdict

	rated current (A) / rated load (W or VA)	1) At 100-200 V rating voltage; 5-150 W for incandescent lamp; 5-150 VA for fluorescent Lamp; electronic step-down converter for extra low-voltage incandescent lamps (for example, halogen); Iron core transformer for extra low-voltage incandescent lamps (for example, halogen); 5-37 VA for self-ballasted fluorescent compact lamp (CFL) or self-ballast LED lamp; 2) At 200-240 V rating voltage; 5-300 W for incandescent lamp; 5-300 VA for fluorescent Lamp; electronic step-down converter for extra low-voltage incandescent lamps (for example, halogen); Iron core transformer for extra low-voltage incandescent lamps (for example, halogen); 5-75 VA for self-ballasted fluorescent compact lamp (CFL) or self-ballast LED lamp	—
--	--	---	---

	rated voltage (V)	100-240 V	—
--	-------------------------	-----------	---

	test voltage between 0,9 and 1,1 Vn (V), whichever is the more unfavourable	264 V	—
--	---	-------	---

parts of the electronic switch	max. measured temperature (°C) 300 W for incandescent lamp	permissible temperature (°C)
Supply cord (L)	57,2	80
Internal surface of enclosure near U1 and PCB side	71,3	Ref.
Terminal block near PCB	92,1	Ref.
Thermal link (F1)	95,2	Ref.
PCB under U1	95,1	T130
Adjusted component near PCB (U1)	90,4	Ref.
Q1 body	102,6	Ref.
Choke (L1)	77,1	Ref.
External surface of enclosure near U1	78,1	95

IEC 60669-2-1			
Clause	Requirement + Test	Result - Remark	Verdict

External surface of enclosure near Q1 body		68,6	95
Terminal block external surface (N)		62,1	95
Adjusted button plastic external surface		26,1	95
Mounting surface		32,2	95
External surface of mounting box (top near relay and fuse)		63,1	95
External surface of mounting box (bottom, near mounting surface)		65,0	95
supplementary information: —			

19.106	TABLE: Test for RCS energized by impulses (under no-load conditions):					N/A
	impulse duration declared by the manufacturer					—
n. specimen	rated control voltage (V)	control voltage of 0,9 times the rated value (V)	20 operations: RCS operates as intended (Yes/No)	control voltage of 1,1 times the rated value (V)	20 operations: RCS operates as intended (Yes/No)	
—	—	—	—	—	—	
supplementary information:						

20.1	TABLE: impact test				P
part of enclosure tested per table 18 (A, B, C, D)	blows per part	height of fall (mm)	comments		
B	4	150	No any damage		
C	4	250	No any damage		
supplementary information:					

21.2	TABLE: ball pressure test of thermoplastic materials				P
	allowed impression diameter (mm): ≤ 2 mm				—
part under test	material designation / manufacturer	test temperature (°C)	impression diameter (mm)		
Plastic bobbin of terminal block	Cixi Xinya Electronics Cable Co., Ltd.	125	1,64		
supplementary information:					

21.3	TABLE: ball pressure test of thermoplastic materials				P
	allowed impression diameter (mm): ≤ 2 mm				—

IEC 60669-2-1			
Clause	Requirement + Test	Result - Remark	Verdict

part under test	material designation / manufacturer	test temperature (°C) ⁽¹⁾	impression diameter (mm)
Plastic enclosure	Bayer Material Science AG	97	0,85

supplementary information:
⁽¹⁾ 70 °C / 40 °C + highest temperature rise determined during the test of clause 17

22.1	TABLE: threaded part torque test					P
threaded part identification	diameter of thread (mm)	column number (I, II, or III)	applied torque (Nm)	times (5/10)	no damage	
Metal screw used in terminal block	3	II	0,5	5	Yes	
supplementary information: —						

23.1	TABLE: creepage distances, clearances and distances through sealing compound							P
	rated voltage (V)	100-240 V						—
item per table 20	creepage distance dcr, clearance cl and distance through sealing compound dtsc at/of:	required cl (mm)	cl (mm)	required dcr (mm)	dcr (mm)	required dtsc (mm)	dtsc (mm)	
1	Between live parts which are separated when the contacts are open	≥ 3	N/A	≥ 3	N/A	≥ 3	N/A	
2	Between live parts of different polarity	≥ 3	3,0	≥ 3	3,0	≥ 3	N/A	
3	Between live parts and accessible surfaces of parts of insulating material	≥ 3	N/A	≥ 3	N/A	≥ 3	N/A	
4	Between live parts and screws or devices for fixing bases and covers	≥ 3	3,0	≥ 3	3,0	≥ 3	N/A	
supplementary information: —								

24.1.1	TABLE: glow-wire test			P
part under test	material designation / manufacturer	test temperature (°C)	remarks	
Plastic enclosure	Bayer Material Science AG	650	No ignition or molten drop	
Plastic bobbin of terminal block	Cixi Xinya Electronics Cable Co., Ltd.	850	No ignition or molten drop	
supplementary information: —				

24.2	TABLE: resistance to tracking		N/A
	number of drops	50	—

IEC 60669-2-1			
Clause	Requirement + Test	Result - Remark	Verdict

part under test	material designation / manufacturer	test voltage (V)	flashover / breakdown (Yes/No)
		175	
supplementary information:			

101.1.1.1	TABLE: fault conditions test		P
	cross-sectional area of conductor not less than 1,5 mm ² (mm ²) (table 15)	2,5 mm ²	—
	terminal screws: torque (Nm) (2/3 table 3 or appropriate figures 1, 2, 3, 4).....	0,34 Nm	—
	type of load	300 W for incandescent Lamp	—
	rated current (A) / rated load (W or VA)	300 W for incandescent Lamp	—
	rated voltage (V)	100-240 V	—
	test voltage between 0,9 and 1,1 V _n (V), whichever is the more unfavourable	240 V x 1,1 = 264 V	—
fault conditions simulated	remarks		verdict
D6 short-circuit	Working as normal, no abnormal; recoverable		P
D1 short-circuit	Working as normal, no abnormal; recoverable		P
D2 short-circuit	Working as normal, no abnormal; recoverable		P
C12 short-circuit	No working, no abnormal; no recoverable		P
C17 short-circuit	Working as normal, no abnormal; recoverable		P
C3 short-circuit	No working, no abnormal; no recoverable, R32 and R33 damage		P
C1 short-circuit	No working, no abnormal; no recoverable, R32 and R33 damage		P
RP1 short-circuit	Circuit protected, no abnormal; recoverable		P
R8 short-circuit	Working as normal, no abnormal; recoverable		P
R31 short-circuit	Working as normal, no abnormal; recoverable		P
U1 (Pin 1 &3) short-circuit	No working, no abnormal; no recoverable, R5, R32 and R33 damage		P
U2 (Pin 1 &3) short-circuit	No working, no abnormal; no recoverable, R32 and R33 damage		P
Q1 (Pin 1 &3) short-circuit	Circuit protected, no abnormal; recoverable		P
Q2 (Pin 1 &3) short-circuit	Circuit protected, no abnormal; recoverable		P
	TABLE: temperature rise measurements		N/A
	temperature measured after (min)		—

IEC 60669-2-1			
Clause	Requirement + Test	Result - Remark	Verdict

parts of the electronic switch		max. measured temperature rise (K)	permissible temperature rise (K)
—		—	—
TABLE: additional temperature rise measurements in case of temperature limited by a fuse			N/A
	current under the relevant fault conditions measured with the fuse short-circuited (A)		—
	type of fuse as specified by IEC 60127		—
	test duration corresponding to the maximum fusing time corresponding to the current measured (min) :		—
parts of the electronic switch		max. measured temperature rise (K)	permissible temperature rise (K)
—		—	—
supplementary information:			

101.1.1.2	TABLE: temperature rise measurements during overload tests		P
	cross-sectional area of conductor not less than 1,5 mm ² (mm ²) (table 15)	2,5 mm ²	—
	terminal screws: torque (Nm) (2/3 table 3 or appropriate figures 1, 2, 3, 4).....	0,34 Nm	—
	rated voltage (V)	100-240 V	—
	test voltage between 0,9 and 1,1 V _n (V), whichever is the more unfavourable	1,1 x 240 V = 264 V	—
parts of the electronic switch		max. measured temperature (°C)	permissible temperature (°C)
Supply cord (L)		69	130
Internal surface of enclosure near U1 and PCB side		88	Ref
Terminal block near PCB		86	Ref
Thermal link (F1)		112	Ref
PCB under U1		114	Ref
Adjusted component near PCB (U1)		114	Ref
Q1 body		109	Ref
Choke (L1)		122	Ref
External surface of enclosure near U1		92	100

IEC 60669-2-1			
Clause	Requirement + Test	Result - Remark	Verdict

External surface of enclosure near Q1 body		84	100
Terminal block external surface (N)		84	100
Adjusted button plastic external surface		60	100
Mounting surface		60	100
External surface of mounting box (top near relay and fuse)		50	100
External surface of mounting box (bottom, near mounting surface)		49	100
supplementary information: test input load is 475 W			

101.3	TABLE: electric strength			P
item per table 14	test voltage applied between:	test voltage (V)	flashover / breakdown (Yes/No)	
1	Between all poles connected together and the body, with switch in "on" position	1500 V	NO	
2	Between live parts and accessible metal parts	2500 V	N/A	
3	Between live parts and metal knobs, push-buttons and the like	3000 V	N/A	
supplementary information: —				

102	TABLE: components					P
object/part No.	manufacturer/ trademark	type/model	technical data	compliance to standard	mark(s) of conformity ¹⁾	
PCB material	Kingboard Laminates Holdings Ltd.	KB-6160	V-0; 130 °C; Min. thickness: 1,6 mm	IEC/EN 60669-2-1 IEC/EN 60669-1	Tested with appliance & UL	
	Shengyi Technology Co., Ltd.	S1141	V-0; 130 °C; Min. thickness: 1,6 mm	IEC/EN 60669-2-1 IEC/EN 60669-1	Tested with appliance & UL	
	International Laminate Material Ltd	ILM-R1##	V-0; 130 °C; Min. thickness: 1,6 mm	IEC/EN 60669-2-1 IEC/EN 60669-1	Tested with appliance & UL	
Thermal link	AUPO Electronics Co., Ltd.	A4-5A-F	AC 250 V; 5 A; 115 °C	IEC/EN 60691	VDE	
Terminal block (J2 and J3)	Cixi Xinya Electronics Cable Co., Ltd.	CM20/40	250 V; 10 A; 1,0-2,5 mm ² ; PA66 bobbin; copper alloy conductor	IEC/EN 60669-2-1 IEC/EN 60669-1	Tested with appliance	
Plastic enclosure	Bayer Material Science AG	2805+(z)(f11)	PC; V-2; Min. thickness 1,0 mm	IEC/EN 60669-2-1 IEC/EN 60669-1	Tested with appliance & UL	
Fiberglass sleeving	Foshan Nanhua Insulation Material Co Ltd	2752-II; 2752-III	Silicone coated fiberglass sleeving	IEC/EN 60669-2-1 IEC/EN 60669-1	Tested with appliance & UL	

IEC 60669-2-1			
Clause	Requirement + Test	Result - Remark	Verdict

Encoder (semiconductor switching device operation component)	Dong Guan Chang Tai Er Electronic., Ltd.	ED11601M-FB15A7.0-C15-202-G153	300 VAC; 2E4 rotational life and 2E4 operating life for push switch	IEC/EN 60669-2-1 IEC/EN 60669-1	Tested with appliance
--	--	--------------------------------	---	------------------------------------	-----------------------

1) an asterisk indicates a mark which assures the agreed level of surveillance

102.4.2	TABLE: temperature rise measurements after test for automatic protective devices which only decrease current to the electronic switch		N/A
	cross-sectional area of conductor not less than 1,5 mm ² (mm ²) (table 15)		—
	terminal screws: torque (Nm) (2/3 table 3 or appropriate figures 1, 2, 3, 4).....		—
	type of load		—
	rated current (A) / rated load (W or VA)		—
	rated voltage (V)		—
	test voltage between 0,9 and 1,1 V _n (V), whichever is the more unfavourable		—
parts of the electronic switch		max. measured temperature rise (K)	permissible temperature rise (K)
supplementary information:			

IEC 60669-2-1			
Clause	Requirement + Test	Result - Remark	Verdict

<p>ATTACHMENT TO TEST REPORT IEC 60669-2-1 EUROPEAN GROUP DIFFERENCES AND NATIONAL DIFFERENCES</p> <p>Switches for household and similar fixed-electrical installations Part 2-1: Particular requirements - Electronic switches</p> <p>Differences according: EN 60669-2-1:2004 + A1: 2009 + A12:2010) (used in conjunction with EN 60669-1:1999 + A1:2002 + A2:2008)</p> <p>Copyright © 2010 IEC System for Conformity Testing and Certification of Electrical Equipment (IECEE), Geneva, Switzerland. All rights reserved.</p>			
--	--	--	--

Clause	Requirement + Test	Result - Remark	Verdict
	CENELEC COMMON MODIFICATIONS (EN)		P
8	MARKING		P
8.1 (Annex B)	Paragraph added at the end of this subclause:		P
	Flexible cable outlet switches: information of minimum and maximum sizes for which the anchorage is provided put on the switch and/or the packaging unit		N/A
8.3	First sentence of last paragraph before note 2 replaced by:		—
	Marking is clearly visible with normal or corrected vision, without additional magnification, marked either on the front of the switch or on the inner part of its associated enclosure, or on the main part of the switch so that it is easy legible during installation		P
8.6	First sentence of the first paragraph replaced by:		—
	Switches of pattern numbers 2, 3, 03 and switches with $V_n > 250$ V and $I_n > 16$ A if marked to indicate the switch position: direction of movement of the actuating member to its different positions or the actual switch position, clearly indicated		N/A
8.8	Note 2 changed into a requirement and its first sentence replaced by:		—
	Special precautions necessary to take when installing the switch: details of these and clear information given in an instruction sheet which accompanies the switch		
9	CHECKING OF DIMENSIONS		P
	Paragraph added after the first paragraph:		—
	Type of boxes in which switches are to be mounted: specified in the manufacturer's catalogue		P
10	PROTECTION AGAINST ELECTRIC SHOCK		P
10.1	Additional requirement (IEC 60669-1/A1) concerning switches designed to be fitted with pilot lights supplied at voltage other than ELV is deleted		—
10.3	First two line replaced by the following:		—

IEC 60669-2-1			
Clause	Requirement + Test	Result - Remark	Verdict
	Accessible parts of switches are made of insulating material		—
	“cover or cover plates” replaced by “cover, cover plates and other parts of the enclosure”		—
10.3.1	Replaced by:		P
	Metal covers, cover plates or other parts of enclosure protected by supplementary insulation made by insulating linings or insulating barriers		P
	Insulating linings or insulating barriers:		P
	- cannot be removed without being permanently damaged, or designed that		P
	- cannot be replaced in an incorrect position; if they are omitted, accessories are rendered inoperable or manifestly incomplete; there is no risk of accidental contact between live parts and metal covers or cover plates; precautions are taken to prevent creepage distances or clearances becoming less than the values specified in clause 23		P
10.3.2	Replaced by:		N/A
	Earthing of metal covers, cover plates or other parts of enclosure: connection of low resistance		N/A
11	PROVISION FOR EARTHING		N/A
11.1	Notes 1 and 2 changed into requirements:		N/A
	Requirement did not apply to the metal cover plates mentioned in 10.3.1		N/A
	Small screws and the like, isolated from live parts, for fixing bases, covers or cover plates, were not considered as accessible parts which can become live in the event of an insulation fault		N/A
11.2	Second paragraph replaced by:		N/A
	Earthing terminals have a capacity not less than that of the corresponding terminals for the supply conductors		N/A
12	TERMINALS		P
12.2.4	Second paragraph replaced by:		
	Terminals the body of which is made of materials as detailed in 22.5 considered as complying with the requirement		P
12.2.5	Paragraph before note 4 deleted		—
12.2.6	“in case where they exist in the relevant IEC standard” in the last paragraph replaced by “if any, according to HD 21.3		P
12.3.1	Present note numbered as note 1 and added new note 2:		—
	Tests of 12.3.12 carried out using rigid solid conductors only		—

IEC 60669-2-1			
Clause	Requirement + Test	Result - Remark	Verdict
13	CONSTRUCTIONAL REQUIREMENTS		N/A
13.16 (Annex B)	First paragraph replaced by:		—
	Flexible cable outlet switches: flexible cable (60245 IEC 66, 60227 IEC 52 or 60227 IEC 53, or as specified by the manufacturer) enter the switch through a suitable hole, groove or gland		N/A
	Last but one paragraph replaced:		N/A
	An a.c. voltage of 2000 V applied for 1 min between the conductors and any metal clamp of the cord anchorage		N/A
	During the test: insulation of flexible cable not damaged (no breakdown or flashover)		N/A
	Subclause added at the end:		N/A
	Flexible cable outlet switches:		N/A
	- clear how relief from strain and prevention of twisting is intended to be effected		N/A
	- cord anchorage, or at least part of it, integral with or permanently fixed to one of the component parts of the switch		N/A
	- makeshift methods not used		N/A
	- cord anchorages suitable for different type of flexible cables		N/A
	Rewirable switches with earthing connection are designed with ample space for slack of the earthing conductor		N/A
19	NORMAL OPERATION		N/A
19.102	Paragraph added after the first paragraph:		N/A
	This is not applicable to dimmers for step-down converters as these accessories are tested according to 19.101		N/A
22	SCREWS, CURRENT-CARRYING PARTS AND CONNECTIONS		P
22.1	Second sentence of the second paragraph deleted		P
23	CREEPAGE DISTANCES, CLEARANCES AND DISTANCES THROUGH SEALING COMPOUND		N/A
23.3	Subclause added:		N/A
	Ordinary surface-type switches do not have bare current-carrying strips at the back		N/A
Table 20	Addition of the following NOTE:		N/A
Note 3	Items 101 and 102 apply to electronic RCS and TDS only		N/A
24	RESISTANCE OF INSULATING MATERIAL TO ABNORMAL HEAT, TO FIRE AND TO TRACKING		P
24.1.1	Item b) replaced by:		P

IEC 60669-2-1			
Clause	Requirement + Test	Result - Remark	Verdict
	Parts of insulating material not necessary to retain current-carrying parts and parts of the earthing circuit in position, even though they are in contact with them, and parts of insulating materials necessary to hold in position the earthing terminal in an enclosure, by the test made at a temperature of 650 °C		P
26	EMC REQUIREMENTS		P
	Electronic switches designed to operate correctly under the conditions of electromagnetic environment in which they are intended to be used		P
26.1	Immunity		P
	Electronic switches designed so that the switch state (ON or OFF) and/or the setting value are protected against interference		P
	Type of load	3) At 100-200 V rating voltage; 5-150 W for incandescent lamp ; 5-150 VA for fluorescent Lamp; electronic step-down converter for extra low-voltage incandescent lamps (for example, halogen); Iron core transformer for extra low-voltage incandescent lamps (for example, halogen); 5-37 VA for self-ballasted fluorescent compact lamp (CFL) or self-ballast LED lamp; 4) At 200-240 V rating voltage; 5-300 W for incandescent lamp; 5-300 VA for fluorescent Lamp; electronic step-down converter for extra low-voltage incandescent lamps (for example, halogen); Iron core transformer for extra low-voltage incandescent lamps (for example, halogen); 5-75 VA for self-ballasted fluorescent compact lamp (CFL) or self-ballast LED lamp	—

IEC 60669-2-1			
Clause	Requirement + Test	Result - Remark	Verdict

	Test current: In (A) / Rated load (W or VA)	1) At 100-200 V rating voltage; 5-150 W for incandescent lamp ; 5-150 VA for fluorescent Lamp; electronic step-down converter for extra low-voltage incandescent lamps (for example, halogen); Iron core transformer for extra low-voltage incandescent lamps (for example, halogen); 5-37 VA for self-ballasted fluorescent compact lamp (CFL) or self-ballast LED lamp; 2) At 200-240 V rating voltage; 5-300 W for incandescent lamp; 5-300 VA for fluorescent Lamp; electronic step-down converter for extra low-voltage incandescent lamps (for example, halogen); Iron core transformer for extra low-voltage incandescent lamps (for example, halogen); 5-75 VA for self-ballasted fluorescent compact lamp (CFL) or self-ballast LED lamp	—
	Test voltage: Vn (V)	100-240	—
	Electronic switches tested, if applicable, in the following states (test parameters referred to table 104):		P
	a) in the ON state		P
	For electronic switches where the setting can alter (e.g. dimming devices) the electronic switch is set at a firing angle of approx. 90° which results in an output power P_o (r.m.s.).		P
	A variation of P_o less than 10 % is not considered to be a change of the setting.		P
	b) in the OFF state		N/A
	For the tests with operation, the electronic switch shall be switched ON/OFF with an operation rate of 1 operation/second or less, or the setting value shall be changed e.g. from minimum to maximum		N/A
	For electronic switches whose cycle of operation is limited by their application (for example, passive infrared, time delay electronic switches, etc.), the rate of operation during the tests shall be specified by the manufacturer.		N/A

IEC 60669-2-1			
Clause	Requirement + Test	Result - Remark	Verdict
26.1.1	Voltage dips and short interruptions		P
	Electronic switch tested using the equipment specified in IEC 61000-4-11 in accordance with table 105: sequence: 3 dips/interruptions (duration: 10 cycles at rated frequency) with interval of 10 s minimum between each test event:		P
	Test level: 0 % U_T		P
	Test level: 40 % U_T		P
	Test level: 70 % U_T		P
	The test shall be done on the power supply lines of the electronic switch.		P
	During the test, the electronic switch is not operated.		P
	During the test, the state and setting of the electronic switch may alter, flickering is neglected		P
	After the test, the electronic switch shall be in the original state and setting and shall operate as intended		P
	After the test, the general purpose electronic switch with included automatic functions shall operate as intended		P
26.1.2	Surge immunity test for 1,2/50 μ s wave impulses		P
	Test carried out according to IEC 61000-4-5 applying two positive discharges and two negative discharges at each of the following angles 0°, 90°, 270°, at a repetition rate of (60 \pm 5) s, with an open-circuit test voltage according to Table 106		P
	During the test, the electronic switch is not operated.		P
	During the test, the state and setting of the electronic switch may alter, flickering is neglected		P
	After the test, the electronic switch shall be in the original state and setting and shall operate as intended		P
	After the test, the general purpose electronic switch with included automatic functions shall operate as intended		P
26.1.3	Electrical fast transient/burst test		P
	Test carried out according to IEC 61000-4-4 in accordance with table 107		P
	During the test, the electronic switch is not operated.		P
	During the test, the state and setting of the electronic switch may alter, flickering caused by the electronic switch is allowed		P
	After the test, the electronic switch shall be in the original state and setting and shall operate as intended		P
	After the test, the general purpose electronic switch with included automatic functions shall operate as intended.		P
26.1.4	Electrostatic discharge test		P

IEC 60669-2-1			
Clause	Requirement + Test	Result - Remark	Verdict
	Electronic switch not intended to operate incandescent lamp: test carried out with only one load of the loads specified within the manufacturer's instructions		P
	Test carried out according to EN 61000-4-2 applying 10 positive and 10 negative discharge:		P
	- contact discharge to the conductive surface and to coupling planes (test voltage: 4 kV)		P
	- air discharge at insulating surfaces (test voltage: 8 kV)		P
	During the test, the electronic switch is not operated.		P
	During the test, the state and setting of the electronic switch may alter, flickering is neglected		P
	After the test, the electronic switch shall be in the original state and setting and shall operate as intended.		P
	After the test, the general purpose electronic switch with included automatic functions shall operate as intended		P
26.1.5	Radiated electromagnetic field test		P
	Test applicable only to electronic switches containing infra-red (IR) receivers, radio frequency receivers, passive infra-red (PIR) devices, devices containing microprocessors or similar		P
	Test is carried out according to EN 61000-4-3 by applying a field strength of 3 V/m in the frequency range 80 MHz to 1 000 MHz and 1 400 Mhz to 2000 MHz with the exception of the exclusion band as defined in the relevant product standard for transmitters, receivers and duplex transceivers		P
	During the test, the electronic switch is operated, if it contains automatic functions or can be remotely controlled		P
	During and after the test, the electronic switch shall operate as intended, flickering is not allowed		P
	Flickering of lamps or irregular running of motors due to switching transients caused by frequency changes of the test equipment during the test procedure is neglected		P
	After the test, the general purpose electronic switch with included automatic functions shall operate as intended		P
26.1.6	Radio-frequency voltage test		P
	Test applicable only to electronic switches containing infra-red (IR) receivers, radio frequency receivers, passive infra-red (PIR) devices, devices containing microprocessors or similar		P

IEC 60669-2-1			
Clause	Requirement + Test	Result - Remark	Verdict
	Test carried out according to IEC 61000-4-6 applying a conducted radio-frequency voltage of 3 V r.m.s. on supply lines and control lines:		P
	During the test, the electronic switch is operated, if it contains automatic functions or can be remotely controlled.		P
	During and after the test, the electronic switch shall operate as intended, flickering is not allowed		P
	Flickering of lamps or irregular running of motors due to switching transients caused by frequency changes of the test equipment during the test procedure is neglected		P
	After the test, the general purpose electronic switch with included automatic functions shall operate as intended		P
26.1.7	Power-frequency magnetic field test		N/A
	Test applicable only to electronic switches containing devices susceptible to magnetic fields, for example, Hall elements, electro dynamic microphones, etc.		N/A
	Test carried out according to IEC 61000-4-8 applying a magnetic field of 3 A/m, 50 Hz:		N/A
	During the test, the electronic switch is operated, if it contains automatic functions or can be remotely controlled..		N/A
	During and after the test, the electronic switch shall operate as intended, flickering is not allowed.		N/A
	Flickering of lamps or irregular running of motors due to switching transients caused by frequency changes of the test equipment during the test procedure is neglected		N/A
	After the test, the general purpose electronic switch with included automatic functions shall operate as intended		N/A
26.2	Emission		P
26.2.1	Low-frequency emission		P
	Electronic switches designed that they do not cause excessive disturbances in the network		N/A
	Electronic switch complies with IEC 61000-3-2 and IEC 61000-3-3		P
	Electronic switches with electromechanically operated contact mechanism (for example, a relay) are deemed to meet the requirements of IEC 61000-3-2 without need for testing. Therefore only the mains supply terminal/terminations of those products shall be tested		N/A
26.2.2	Radio-frequency emission		P
	Electronic switches designed that they do not cause excessive radio interference		P

IEC 60669-2-1			
Clause	Requirement + Test	Result - Remark	Verdict
	a) Electronic switch complies with the requirements of EN 55014: 2006 (sub clause 8.1.4.1) at the mains terminals		N/A
	b) Electronic switch complies with the requirements of EN 55015: 2006 (sub clause 8.1.4.2) at the load and/or control terminals		P
101	ABNORMAL CONDITIONS		N/A
101.1.1.2	Addition of the following NOTE:		N/A
	The tripping current of the protective devices (e.g. fuses, automatic protective devices, etc.) to be used for the verification of electronic switches without incorporated temperature-limiting devices and without incorporated fuses is in accordance with the rated current of the protective device, specified by the manufacturer, intended to protect the electronic switch		N/A
	Information regarding the protective device which is intended to protect the electronic switch are specified by the manufacturers in the instruction sheets provided with the products		N/A
102	COMPONENTS		N/A
102.4.1.2	Note replaced by the following test requirement:		N/A
	For cut-outs in electronic switches for fluorescent lamps, the tests are carried out in the same way as for electronic switches for incandescent lamps		N/A
ZB	ANNEX ZB, SPECIAL NATIONAL CONDITIONS		N/A
7.1.7	BELGIUM, CZECH REPUBLIC, FINLAND, GERMANY, NETHERLANDS, NORWAY, SWEDEN: design B not used due to installation practice		N/A
8.1	DENMARK: symbol for earth for any space provided for an earthing terminal		N/A
	UNITED KINGDOM: marking of type reference not used		N/A
8.3	UNITED KINGDOM: marking of type reference not used		N/A
10.2	DENMARK, NORWAY: accessories requiring earth connection cannot normally be used due to the lack of an earthing conductor in many existing old buildings		N/A
10.3	DENMARK: enclosures, including covers and cover plates, may be made of metal:		N/A
	- for ordinary switches which comply with 10.3.1		N/A
	- for switches with IP>X0 which fulfil with 10.3.1 or 10.3.2		N/A

IEC 60669-2-1			
Clause	Requirement + Test	Result - Remark	Verdict

10.3.2	DENMARK, NORWAY: accessories requiring earth connection cannot normally be used due to the lack of an earthing conductor in many existing old buildings		N/A
10.5	DENMARK, NORWAY: accessories requiring earth connection cannot normally be used due to the lack of an earthing conductor in many existing old buildings		N/A
12.2.5	DENMARK, FINLAND, NORWAY, SWEDEN: - additional test with rigid solid conductors (if exist in relevant IEC standard), if the first test has been made with rigid stranded conductors		N/A
	- in the case rigid stranded conductors do not exist, the test may be made with rigid solid conductors only		N/A
12.2.6	DENMARK, FINLAND, NORWAY, SWEDEN: additional test with one rigid solid conductor and one rigid stranded conductor with same cross-sectional areas connected at same time is required for terminals allowing the connection of two conductors		N/A
13.15.2	DENMARK, FINLAND, NORWAY, SWEDEN, SWITZERLAND: sub-clause mandatory		N/A
13.103	DENMARK, FINLAND, NORWAY, SWEDEN, SWITZERLAND, UNITED KINGDOM: Flexible cables complying with electrical strength test only are not allowed for external use		N/A
101.1.1.2	BELGIUM, FRANCE, SPAIN, SWITZERLAND: Electronic switches designed without an associated incorporated protection are loaded for one hour with the conventional tripping current of the associated protection of the lighting circuit (10 A for fuses and 16 A for CB's)		N/A
102.1	UNITED KINGDOM: Fuses according to BS 646 and BS 1362 are deemed to satisfy this requirement		N/A

ZC	ANNEX ZC, A-DEVIATIONS		N/A
11.2	BELGIUM: earthing terminals have a capacity not less than that of corresponding terminals for the supply conductors except that any additional external earthing terminal shall be of a size suitable for conductors of at least 4 mm ²		
13.103	DENMARK (Stærkstømbekendtgørelsen- Elektriske Installationer 2001, § 521.7.4)		N/A
	The insulation of external flexible cable complies with or is at least electrically and mechanically equivalent to that of flexible cables according to HD 21 or HD 22		N/A
13.103	FINLAND (Electrical Safety Act 410/1996, Degree of Ministry of Trade and Industry No. 1193/99, paragraph 4 Publication S10-2002 of the Finnish Safety Technology Authority, Finnish wiring rules SFS 6000-5-52 (HD 384.5.52), Clause 521, Table 52F)		N/A

IEC 60669-2-1			
Clause	Requirement + Test	Result - Remark	Verdict
	The insulation of external flexible cable complies with or is at least electrically and mechanically equivalent to that of flexible cables according to HD 21 or HD 22		N/A
13.103	NORWAY (DSB: FEL 1998 §28 and §10, NEK 400:2002 Clauses 520.1 and 521.1 and Table 52A)		N/A
	Cables with basic insulation are not accepted as wiring external to the switch. The insulation of external flexible cable complies with or is at least electrically and mechanical equivalent to that of flexible cables according to HD 21 or HD 22		N/A
	Cables complying with the electric strength test only are regarded as internal cables and are accepted to be installed in enclosures, conduits, ducting and trunking systems and the like		N/A
13.103	SWEDEN (ELSÄK-FS: 1999:5, Clauses 520.1 and 521.1 and Table 52-1)		N/A
	Cables with basic insulation are not accepted as wiring external to the switch. The insulation of external flexible cable complies with or is at least electrically and mechanical equivalent to that of flexible cables according to HD 21 or HD 22		N/A
	Cables complying with the electric strength test only are regarded as internal cables and are accepted to be installed in enclosures, conduits, ducting and trunking systems and the like		N/A

Appendix: product photos

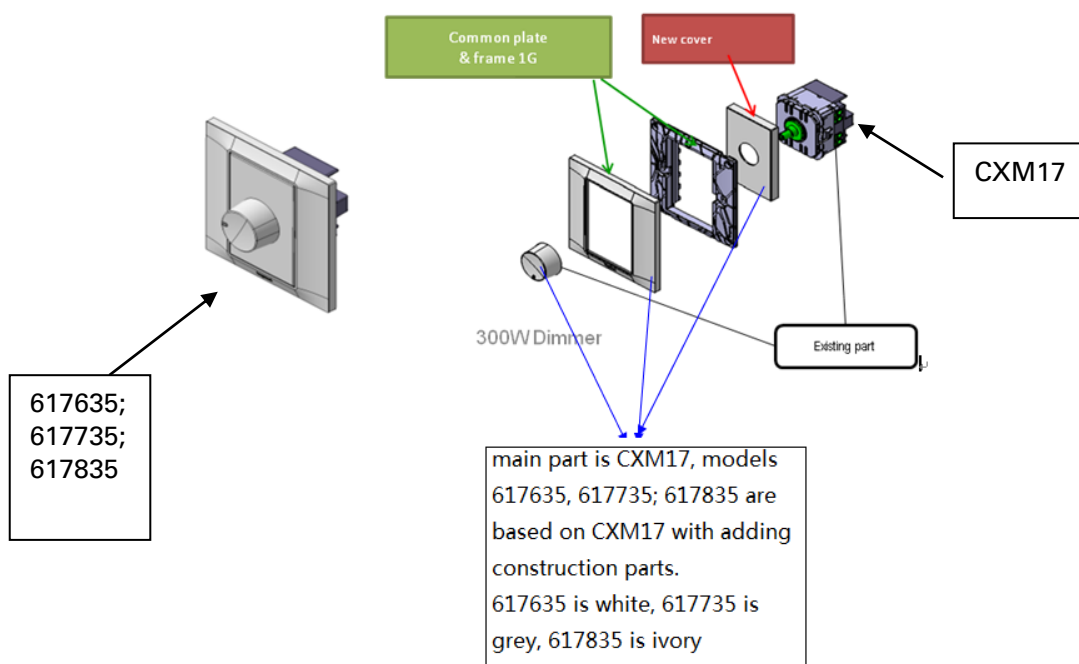
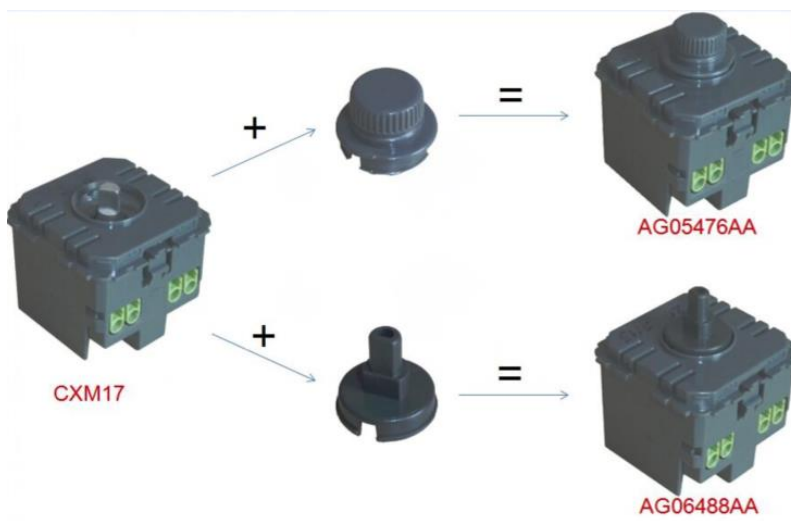

Relationship between models covered by this test report

Remark: all models are identical except the rotary button shape and model description.

Appendix: product photos



Front view of model AG05476AA

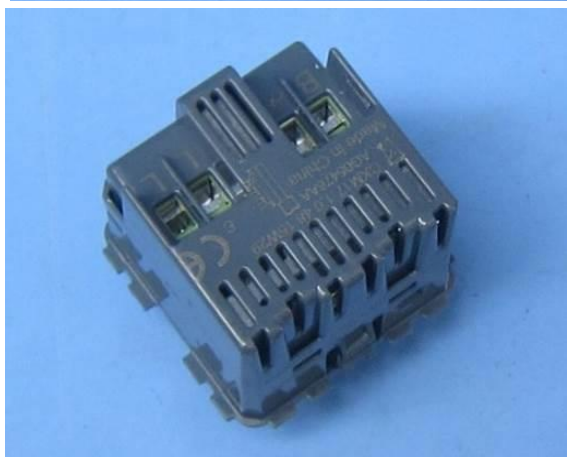

Side view of model AG05476AA

Remark: marking shown on product photos is only for position reference, detail of the marking contents refer to "Copy of marking plate".

Appendix: product photos



Front view of model AG05476AA after plastic cap removed



View of model AG06488AA (left); CXM17 (right)

Appendix: product photos



Exploded view of model CXM17

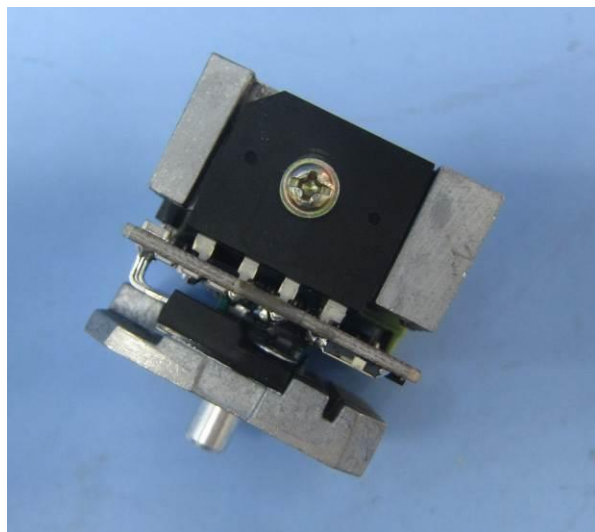
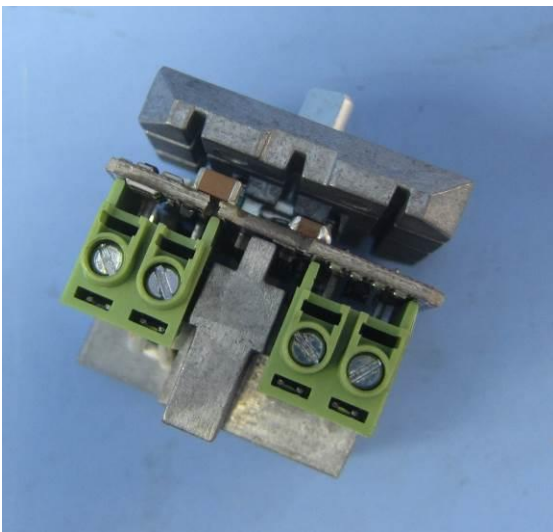

Electrical parts view of model CXM17

Appendix: product photos

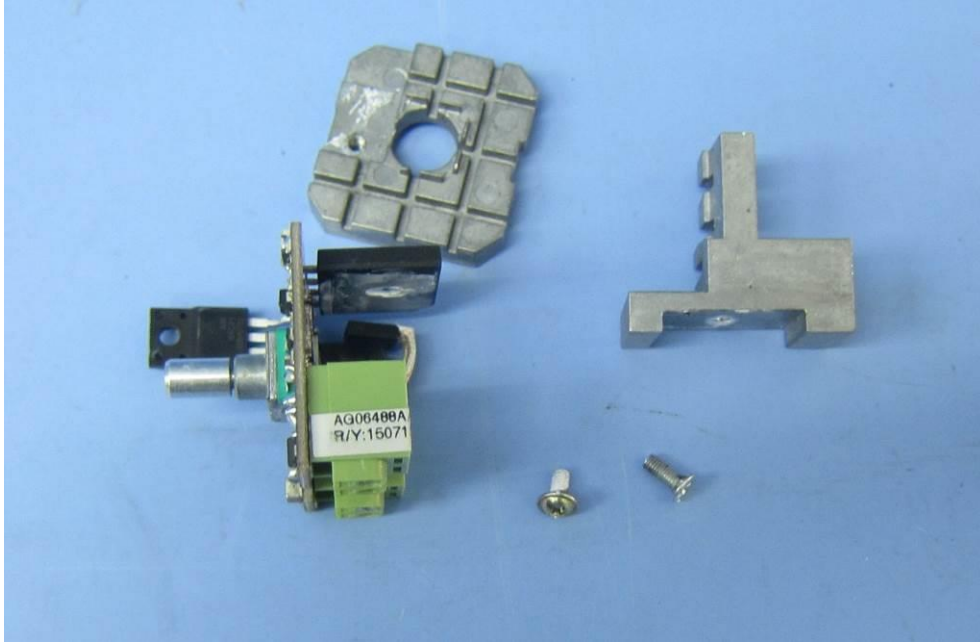

Electrical parts view of model CXM17 after heat sink removed

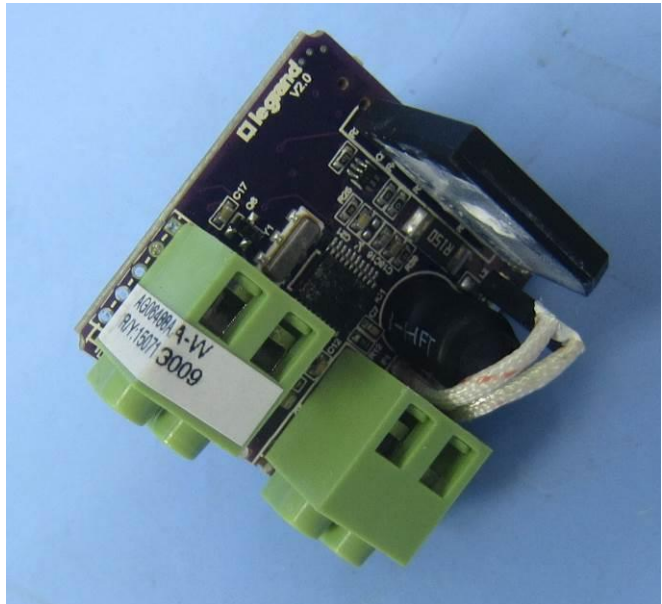
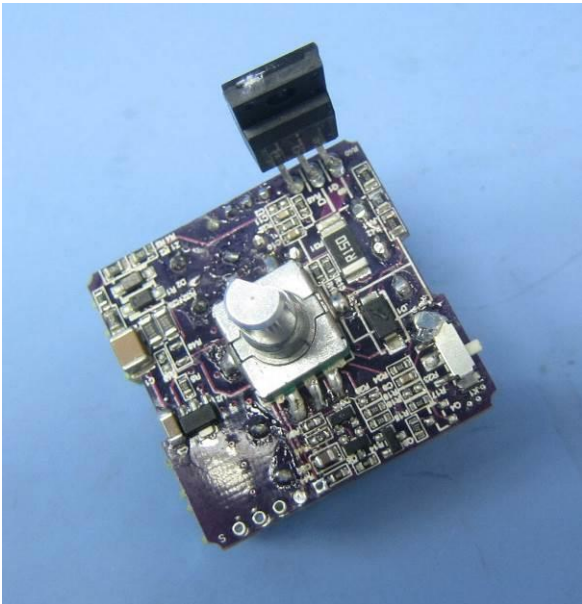

PCB view detail of model CXM17

Appendix: product photos

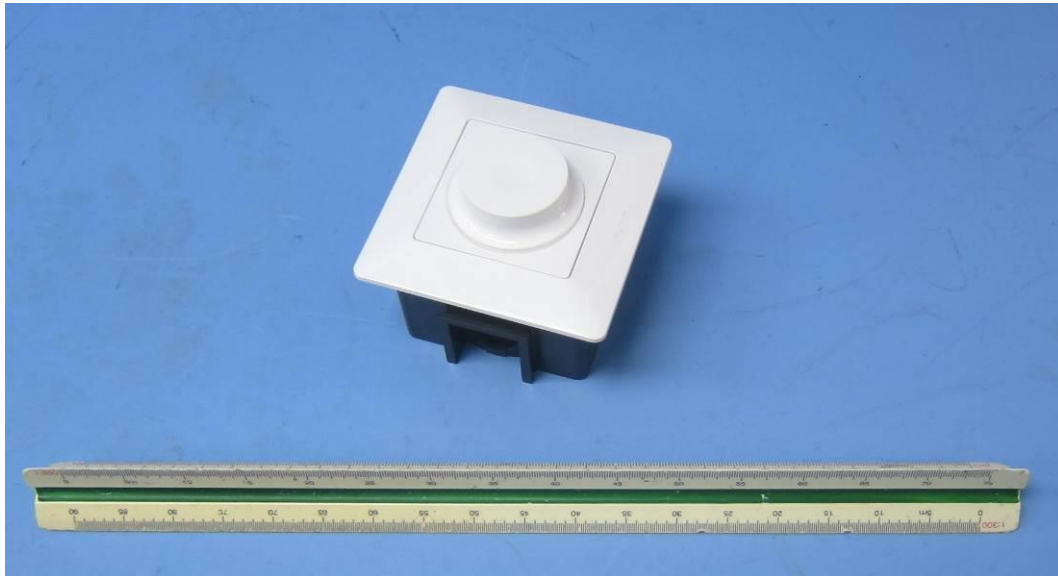

Front view of mounting box (for example) for AG05476AA; AG06488AA



Back view of mounting box (for example) for AG05476AA; AG06488AA

Appendix: product photos



Exploded view of mounting box (for example) for AG05476AA; AG06488AA after external plastic cap removed

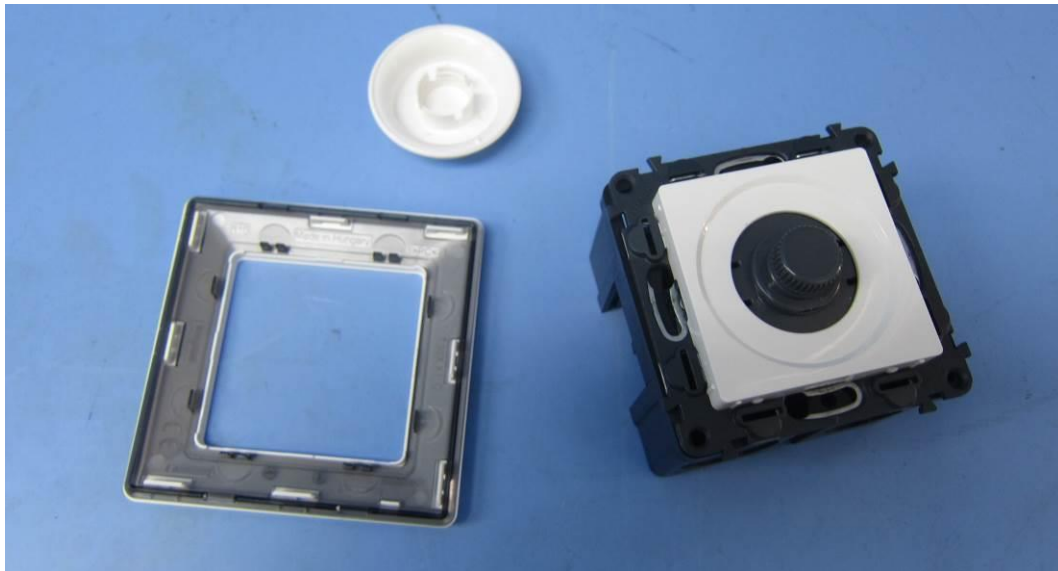

Exploded view I of mounting box (for example) for AG05476AA; AG06488AA

Appendix: product photos



Exploded view II of mounting box (for example) for AG05476AA; AG06488AA

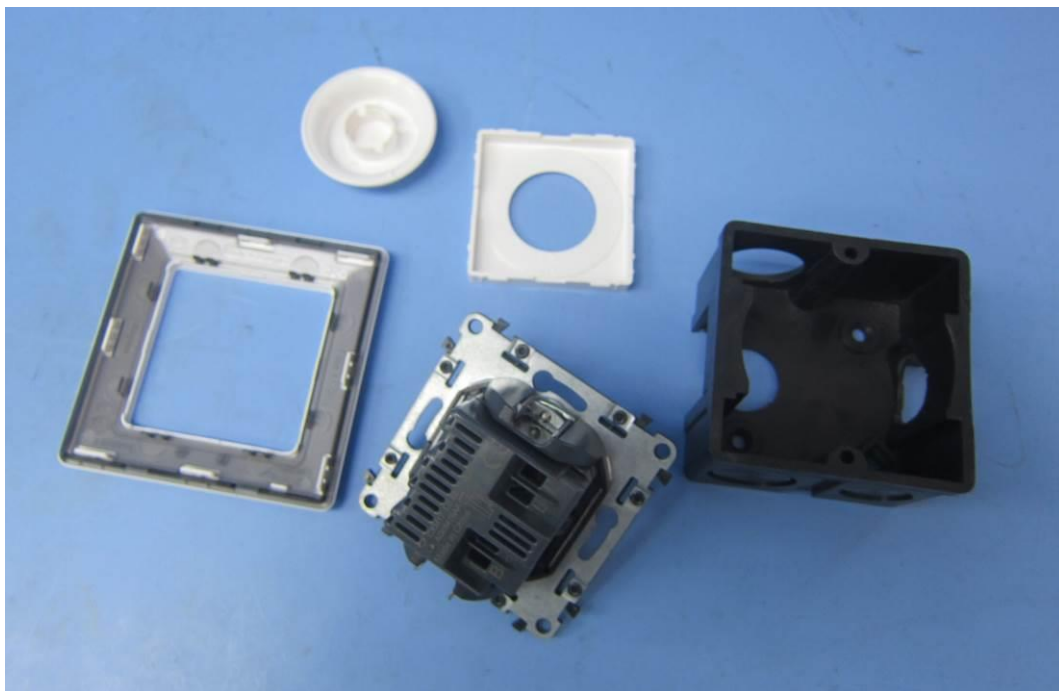

Exploded view III of mounting box (for example) for AG05476AA; AG06488AA

Appendix: product photos

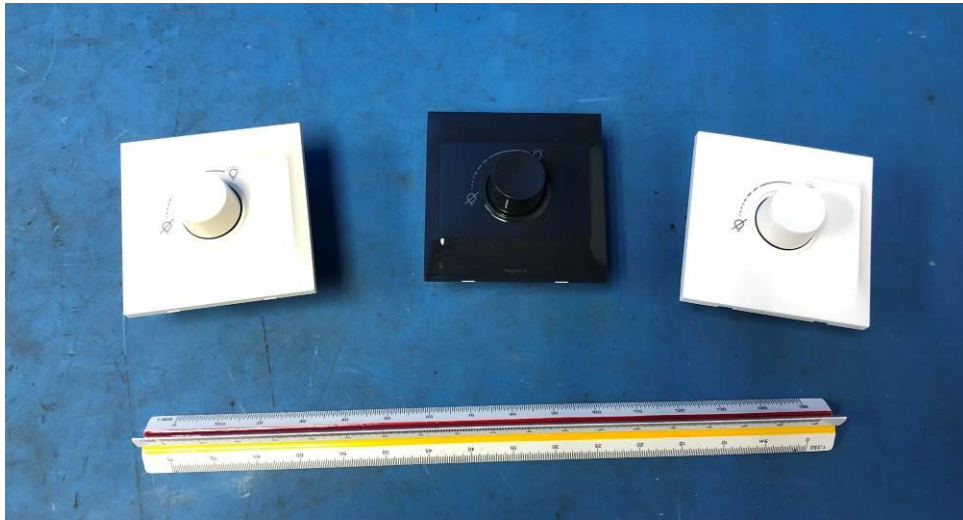

Overview for 617635; 617735; 617835

Remark: the only difference between 3 models is color of enclosure, 617635 is white, 617735 is grey, 617835 is ivory

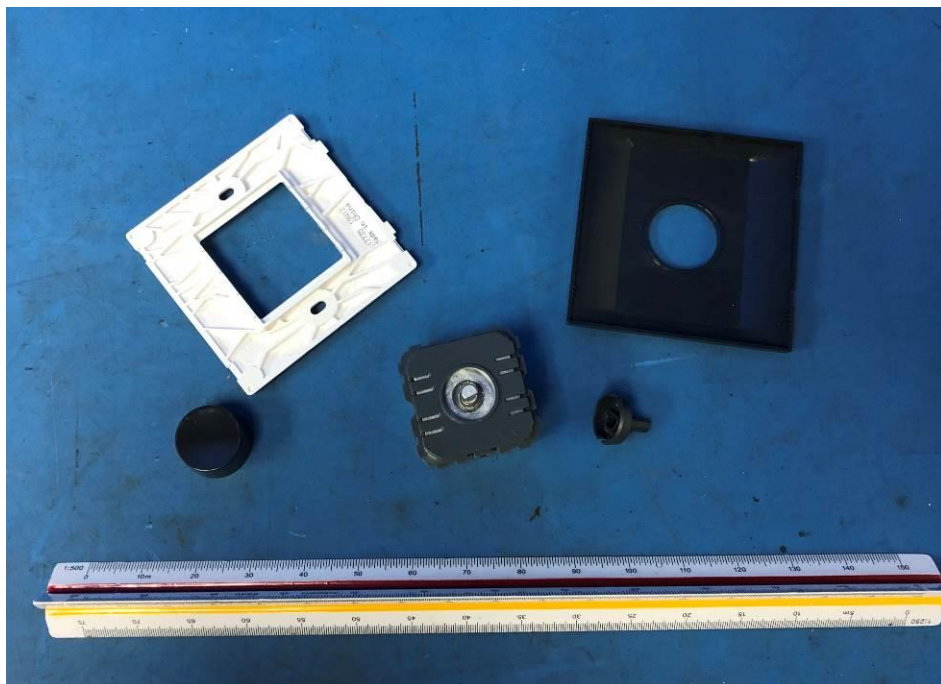

Dissemble view for model 617735

Appendix: product photos

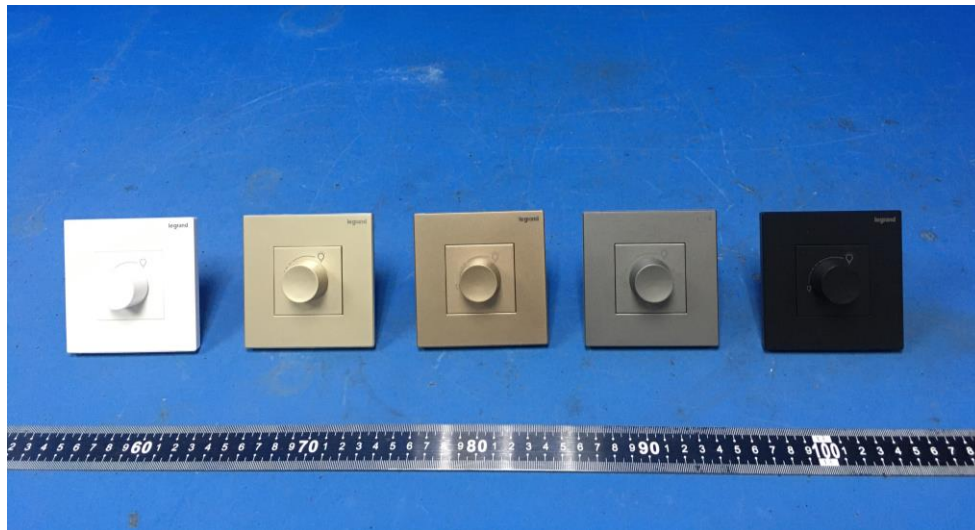

282419 series (only difference is the color of appearance)



Back view of 282419 series

Appendix: product photos

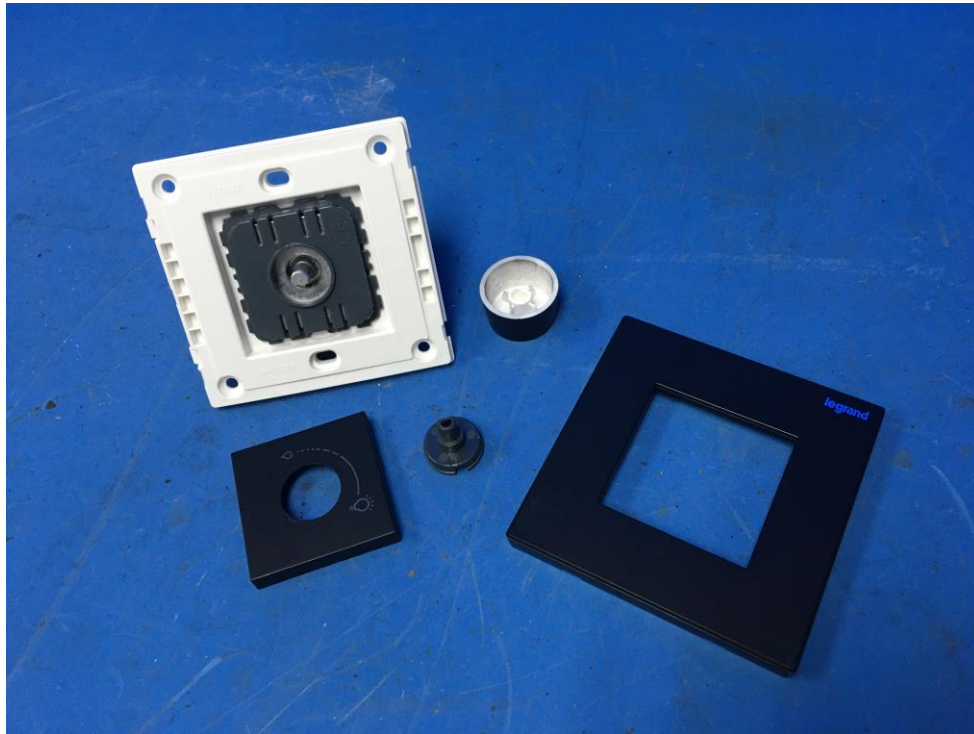

Exploded view I of 282419 series

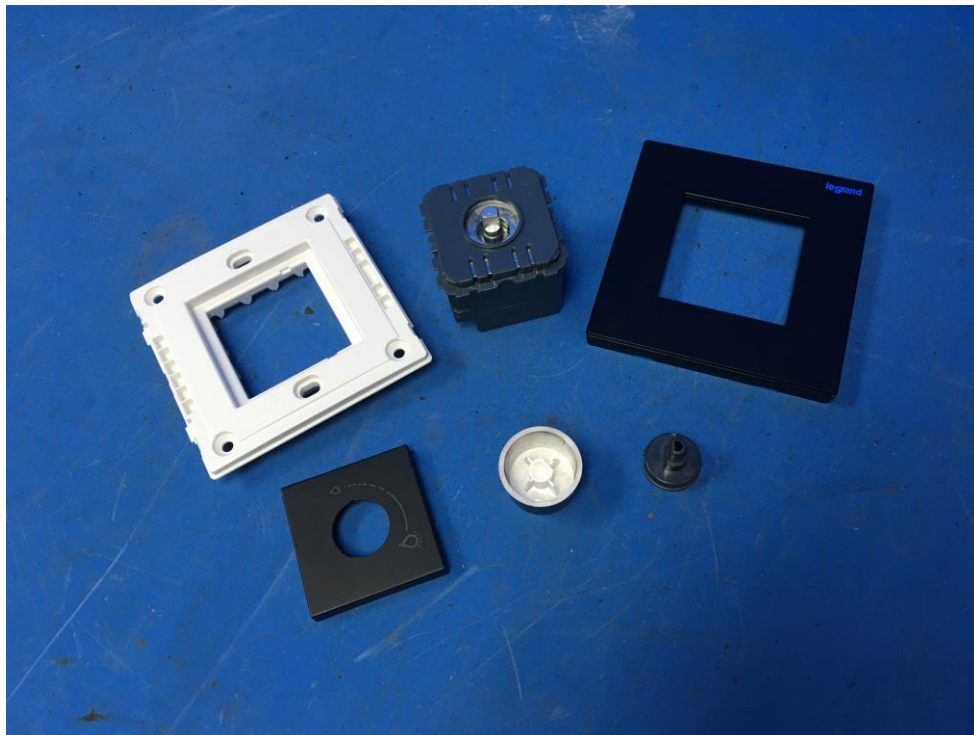

Exploded view II of 282419 series

Appendix: product photos



View of actuating member

Appendix: product photos



Model 731151



Model 731151

Appendix: product photos

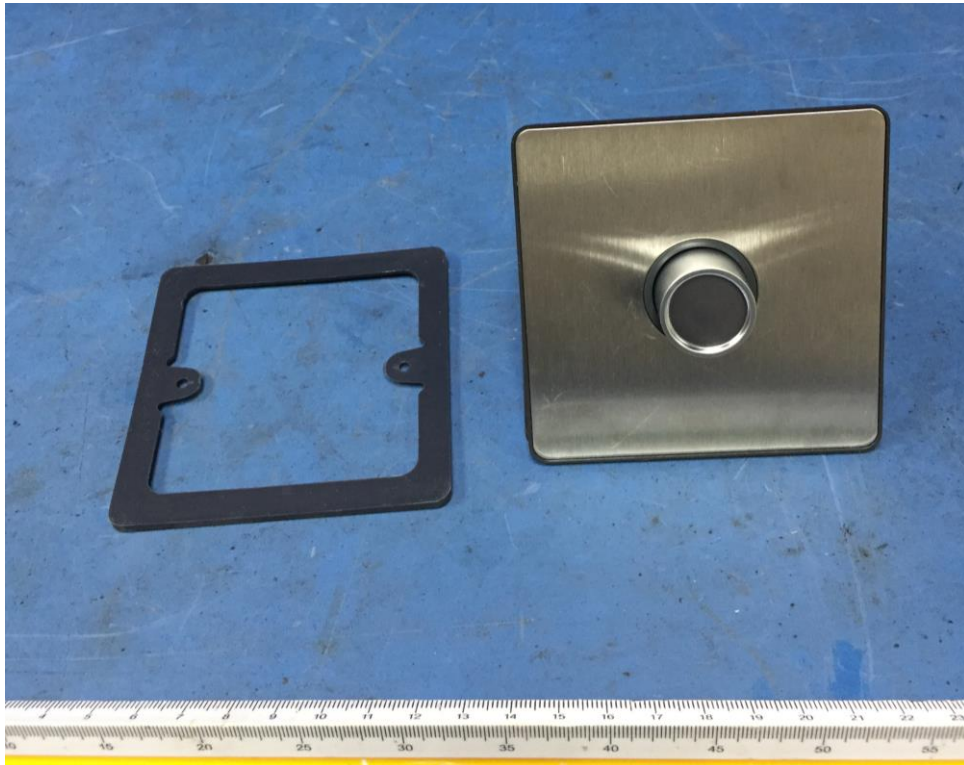

Model 833151, same as 832151

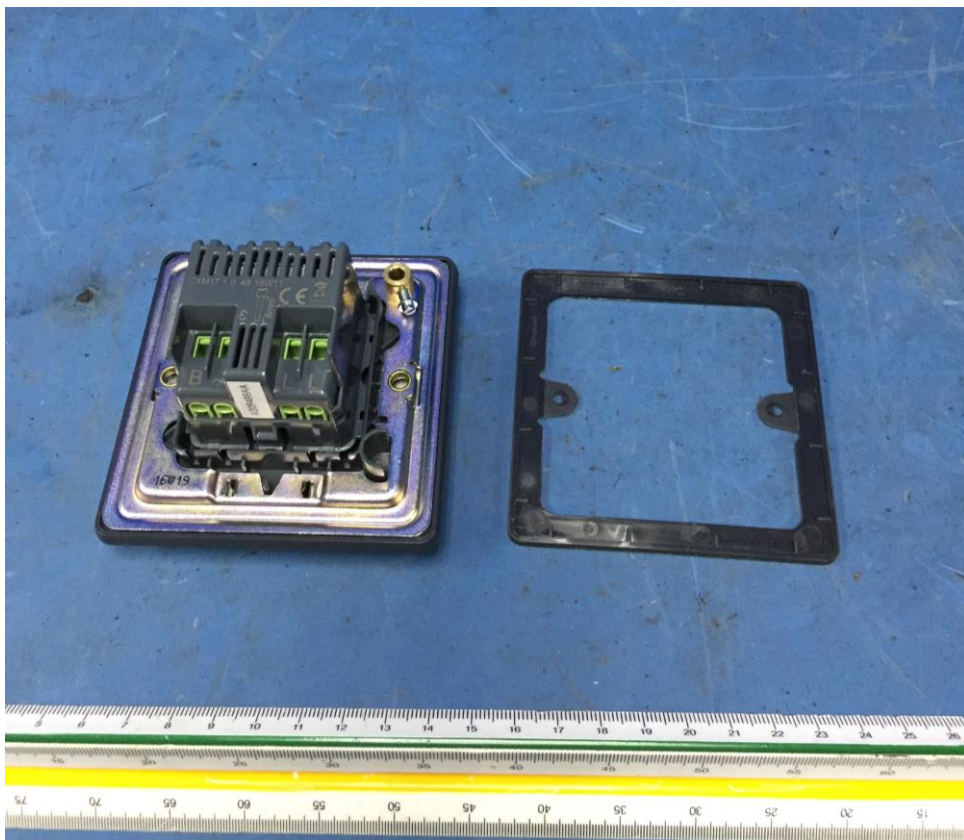

Model 833151, same as 832151

***** End of report *****